

# RDS TECHNOLOGY

TOPCON POSITIONING GROUP



## Agri-Spread Apollo II

Lime / Granular Fertiliser  
Spreader Controller System

Calibration and Operation

RDS Part No.: S/DC/500-10-847  
Document Issue: A : 5.4.16



---

## **Electromagnetic Compatibility (EMC)**

This product complies with European Council Directive 2014/30/EU when installed and used in accordance with the relevant instructions.

## **Service and Technical Support**

PLEASE CONTACT AGRI-SPREAD

If unknown then fax +44 (0) 1453 733311 for further information.

Our policy is one of continuous improvement and the information in this document is subject to change without notice. Check that the software reference matches that displayed by the instrument.

© Copyright RDS Technology Ltd 2016

\UK847-A.DOC

Software Reference: IS600000rev74

<b>1</b>	<b>INTRODUCTION</b>	<b>4</b>
<b>1.1</b>	<b>Apollo II System Overview</b>	<b>4</b>
1.1.1	Basic System.....	4
1.1.2	Touchscreen .....	5
<b>2</b>	<b>X25 BASIC CONTROLS AND SETUP</b>	<b>6</b>
<b>2.1</b>	<b>X25 Start up and Shut down</b>	<b>6</b>
2.1.1	Starting the Console .....	6
2.1.2	Shutting down the console .....	6
<b>2.2</b>	<b>X25 Operation screen controls</b>	<b>7</b>
2.2.1	Navigation bar.....	7
2.2.2	View controls .....	7
2.2.3	Guidance toolbar.....	8
2.2.4	Moving map display - Implement color indicators .....	9
2.2.5	X25 Master Switch Status .....	9
<b>2.3</b>	<b>Using the console toolbar</b>	<b>9</b>
<b>2.4</b>	<b>Agrispread setup</b>	<b>10</b>
2.4.1	Fileserver.....	10
2.4.2	Auto Section Control .....	10
2.4.3	GPS Receiver and Serial port.....	11
2.4.4	Universal terminal softkey layout .....	11
2.4.5	Implement setup.....	12
2.4.6	Master Switch .....	13
2.4.7	Forward Speed Setup.....	13
<b>2.5</b>	<b>Region settings</b>	<b>14</b>
2.5.1	Language set up .....	14
2.5.2	Time/ date set up .....	14
2.5.3	Units setup .....	14
<b>3.</b>	<b>APOLLO II OPERATION</b>	<b>15</b>
<b>3.1</b>	<b>Loading the application</b>	<b>15</b>
<b>3.2</b>	<b>Universal Terminal window</b>	<b>15</b>
<b>3.3</b>	<b>Apollo primary screen pages</b>	<b>16</b>
<b>3.4</b>	<b>The Main Operating screen</b>	<b>16</b>
3.4.1	Spreader Master Switch Status .....	17
3.4.2	Auto / Manual Spinner speed control.....	17
3.4.3	Automatic rate control mode and setting a target rate.....	18
3.4.4	Varying the application rate in auto mode .....	18
3.4.5	Manual rate control mode .....	18
3.4.6	Pre-Start .....	18
3.4.7	Border reduction .....	19
<b>3.5</b>	<b>Totals Screen</b>	<b>19</b>
<b>3.6</b>	<b>Add weight / Tare</b>	<b>20</b>
3.6.1	Machines with loadcells .....	20
3.6.2	Machines without loadcells .....	20

<b>4</b>	<b>JOB MANAGEMENT AND VARIABLE RATE CONTROL (VRC)</b>	<b>21</b>
<b>4.1</b>	<b>Field setup</b>	<b>21</b>
4.1.1	Creating a new client / farm / field.....	21
4.1.2	Selecting a client / farm / field.....	21
4.1.3	Setting a new boundary.....	21
4.1.4	Unloading a field.....	22
<b>4.2</b>	<b>Job Setup</b>	<b>23</b>
4.2.1	Creating a new job.....	23
4.2.2	Selecting an existing job.....	23
4.2.3	Clearing a job.....	23
<b>4.3</b>	<b>Using variable rate control (VRC)</b>	<b>24</b>
4.3.1	Loading a Variable Rate Map.....	24
<b>4.4</b>	<b>Auto section control (ASC)</b>	<b>26</b>
<b>5.</b>	<b>APOLLO II SETUP</b>	<b>27</b>
<b>5.1</b>	<b>'Main Menu' Screen</b>	<b>27</b>
<b>5.2</b>	<b>Product setup</b>	<b>28</b>
5.2.1	Select a product.....	28
5.2.2	Other product settings.....	28
<b>5.3</b>	<b>Alarm setup</b>	<b>28</b>
<b>5.4</b>	<b>Pre-Start setup</b>	<b>29</b>
<b>5.5</b>	<b>Border reduction setup</b>	<b>29</b>
<b>5.6</b>	<b>Width Setup</b>	<b>29</b>
<b>5.7</b>	<b>Forward Speed Setup</b>	<b>30</b>
5.7.1	Forward Speed Input.....	30
5.7.2	SSF Autocal.....	30
5.7.3	Simulated Speed.....	30
<b>6.</b>	<b>PRODUCT CALIBRATION</b>	<b>31</b>
<b>6.1</b>	<b>Calibration mode (with loadcells)</b>	<b>32</b>
6.1.1	Selecting Dynamic / Static Calibration Mode.....	32
6.1.2	Static mode.....	32
6.1.3	Dynamic ('DYN') mode.....	32
<b>6.2</b>	<b>Calibration routine (with or without loadcells)</b>	<b>33</b>
6.2.1	Product Flow Factor – "Check calibration" routine.....	34
<b>6.3</b>	<b>Nudge Calibration</b>	<b>35</b>
<b>6.4</b>	<b>Loadcell calibration</b>	<b>36</b>
<b>6.5</b>	<b>Valve calibration</b>	<b>37</b>
<b>7.</b>	<b>APPENDICES</b>	<b>38</b>
<b>7.1</b>	<b>Software upload</b>	<b>38</b>

# 1 Introduction

## 1.1 Apollo II System Overview

### 1.1.1 Basic System

The Apollo II is an ISOBUS UT-compliant monitoring and application control system for self-propelled / trailed belt spreaders spreading lime / granular materials. Forward speed measurement and cutout sensing enables full proportional control, to maintain (within limits) a set application irrespective of changes in forward speed.

Here is a typical retrofitted system (that is independent from the tractor ISOBUS). Some installations will have minor variations, but the key components are the X25 Console, Spreader ECU, Load Cell ECU and Loadcells.

Figure 1: ISOBUS Apollo II System

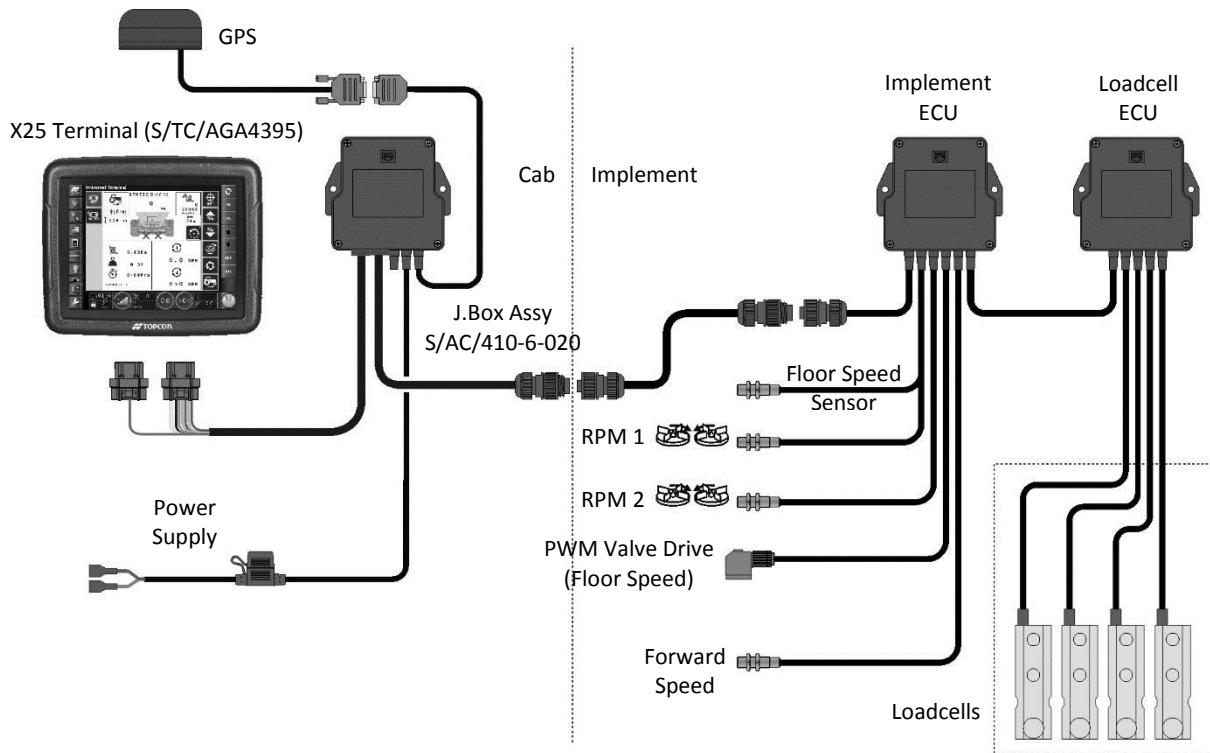

Forward speed sensing may be either a simple magnetic sensor measuring wheel or propshaft rotation (fitted either to the tractor/self-propelled spreader, or trailed spreader), a radar sensor, or via a GPS VTG message. There is no physical master cutout switch. The master on/off switch is 'virtual' i.e. a softkey on the Apollo operation screen.

Master cutout status is detected via a switch in the cab, or a hydraulic switch on the spreader.

The system may be fitted with or without loadcells.

**Machines without loadcells:** The system relies on volumetric calculation from the known gate height and width, and a known product density (or selecting the product from a pre-defined list). It works best for relatively free-flowing material of consistent density.

**Machines with loadcells:** Loadcells enable fully-automatic, continuous calibration. They are advantageous for controlling the rate of material with more variable density. By constantly measuring the weight of product in the spreader, the floor speed is continuously adjusted to achieve the correct target application rate. The system therefore quickly reacts to changes in product characteristics or spreading conditions without having to adjust or re-calibrate the machine.

Other spreader functions such as spinner speed can also be monitored, with warnings being triggered if they are not operating correctly.

### 1.1.2 Touchscreen

---

The instrument has a touch screen. It consists of a polyester film outer layer that must be treated with respect, compared to a non-touch display with toughened instrument glass. Therefore, please observe the following,



**DO NOT use a sharp-pointed object - the screen will be damaged beyond repair!**

**Do NOT wipe or otherwise attempt to clean using any kind of solvent cleaner!.**

**Do NOT wipe using a dirty cloth or gloves. Use only computer screen wipes designed for the purpose!.**

*You may use a blunt, smooth-ended plastic object (e.g. a pen body / cap) as a stylus, if found necessary!*

## 2 X25 Basic Controls and Setup

### 2.1 X25 Start up and Shut down

#### 2.1.1 Starting the Console

1. Press and Hold the Green button on the rear of the console for a few seconds.

**NOTE:** To change the language on the console, select



2. Read the Warning Screen. Scroll to the base of the screen and if you agree select **YES**.

**NOTE:** Selecting 'Yes' confirms your understanding and accepts your responsibility for liabilities described in the Warning Screen.

The console may display the following warning.

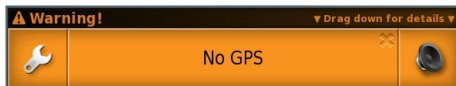

To acknowledge the alarm, press the center of the alarm window. Note that extra details may be displayed for some alarms by dragging the window downwards. Confirm the GPS receiver is connected correctly and communicating. If the warning appears again, this should be remedied during Setup.

The console then displays the Operating Screen (see 1.3). The central area displays the application that was last running when the console was shut down.



#### 2.1.2 Shutting down the console

Swipe up from the base of the screen to display the console toolbar and select the OFF icon.

Alternatively, to shut down the console, briefly press the green ON/OFF button.

The system will ask if you want to power down. Select "Yes" to turn off or "No" to continue working.

**Note:** Pressing and holding the green ON/OFF button will also shut down the console, however data may be lost and this method is not recommended.

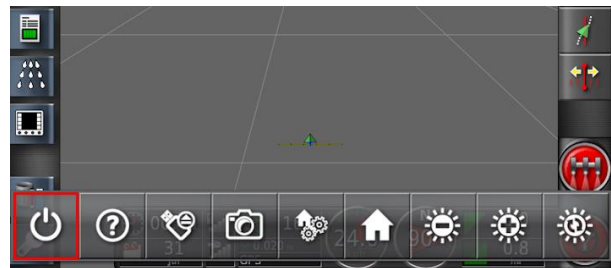



## 2.2 X25 Operation screen controls

The Operation screen is the home screen, indicating the position and direction of the vehicle and its implement as a moving map display.

**NOTE:** The default home screen layout is shown. However the screen layout is user-configurable from the console toolbar (2.3) and therefore keys may not appear exactly as shown. For more comprehensive information on individual controls, please refer to the Topcon X25 Console - Guidance and Autosteering manual

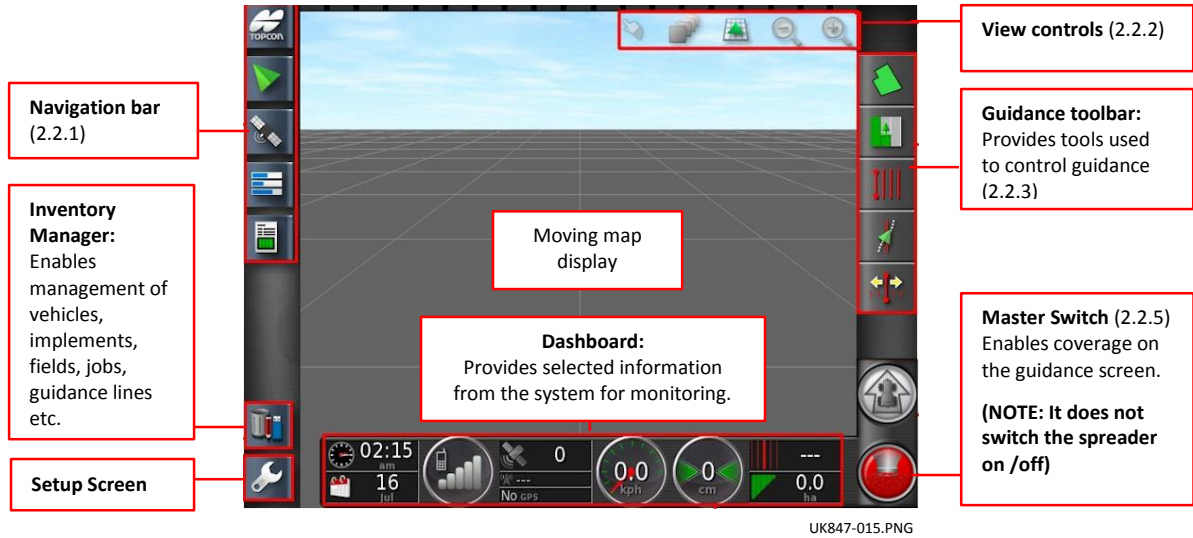









### 2.2.1 Navigation bar



To access other parts of the system, touch a key to open a "mini-view". Touch  or swipe the mini-view from left to right to maximise the window.

You can swipe up or down the navigation bar to access the full range of functions shown below, including the ISOBUS universal terminal (UT).

	System information		Job Information
	Guidance		Auto Section Control (ASC)
	GPS Information		Spreader
	System Diagnostics		ISOBUS universal terminal (UT)

### 2.2.2 View controls











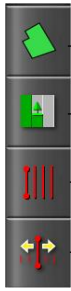



Allows the user to control what is displayed on the guidance map and how it displays.







- Zoom In
- Zoom Out
- Toggle map view mode
- Select visible map layers





### 2.2.3 Guidance toolbar







Provides tools used to control guidance.



Field menu			
	Select field		Boundary recording offset
	New field		Configure headland
	Unload field		Clear field boundary
	Set flag point		Create boundary from shapefile
	Record field boundary		Create boundary from coverage
	Complete field boundary recording		

Job menu			
	Select job		Record job details
	Create new job		Clear job data
	Configure job regions		Data exchange
	Configure variable rate control (VRC)		

Guideline menu			
	Change guidance mode		Set A point
	Select guideline		Open manual AB line entry window
	Create new AB line		

Nudge menu			
	Open nudge options		Nudge guideline to vehicle's position
	Nudge guideline to right		Save nudged guideline
	Nudge guideline to left		GPS drift compensation

### 2.2.4 Moving map display - Implement color indicators



This indicates the position and direction of the vehicle and its implement. The implement color indicates product application status:

- **Red:** Section is off.
- **Blue:** Section is inhibited (on and not flowing, typically due to low speed or pressure).
- **Yellow:** Section is on and not flowing intentionally (typically due to auto-section control stopping the flow).
- **Green:** Section is on and flowing.
- **Orange:** Section is on and not flowing unintentionally or OFF but still flowing unintentionally (typically due to a delay in the time it takes for the flow to start up).

### 2.2.5 X25 Master Switch Status



The Master Switch key activates / deactivates coverage only as indicated on the guidance screen.

**Indicates that coverage is deactivated.**

Coverage cannot be activated if one or more parameters as shown by the “Master Switch Status” window are not met (red).



**Indicates coverage is ready to activate / active.**

Coverage can be activated when all the listed parameters on the “Master Switch Status” window are met (green). The moving map display will then show the section and flow status (2.2.4).

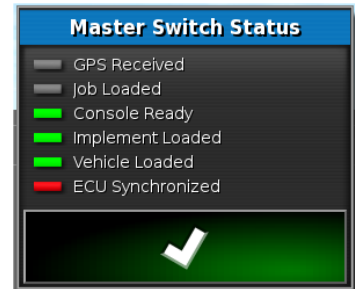

*NOTE: The Master Switch does not switch the spreader in or out of work.*

*(The spreader is switched on/off by the  /  softkeys on the UT Apollo screen).*

## 2.3 Using the console toolbar

The console toolbar is displayed by swiping upwards from the base of the screen.



#### Power off button

The power off button may be used to shut down the console.



#### Help

The Help hint feature displays the names of the user interface elements on the screen. Touch the Help icon on the base of the screen. Question marks appear on the screen next to the icons. Select the screen element showing a question mark to view the names.



#### USB eject

The USB port is on the rear of the console. This can be used to import data to and export data from the console. Before removing the USB, always disconnect first by touching the USB eject icon. A message will display that it is safe to remove the USB.



### Screenshots

Use the screenshot icon to take screenshots (which are stored on the USB). Press the USB eject icon before unplugging the USB.



### Manage global home screens

Enables Operation screen layouts to be saved. This may be useful to declutter the Operation screen or quickly return to displaying required information. Display/hide the required views on the Operation screen and select Save Home Screen to save the layout.



### Go to Home Screen

Displays a list of saved global home screens or toggles between saved screens.



### Brightness control

Brightness control adjusts the brightness of the display. Use plus or minus to adjust display.



### Day/night mode

Day/night mode changes the brightness of the display. Settings are Day, Night and Auto. Auto light mode will set the brightness automatically, depending on light conditions.

## 2.4 Agrispread setup

Touching



on the Operation screen accesses the Setup screen. Touching



returns to the Operation screen

### 2.4.1 Fileserver

1. Select 'System Settings' > 'Features' > 'Console'
2. Check "FILESERVER" is enabled.



UK847-050.PNG

### 2.4.2 Auto Section Control

1. Select 'System Settings' > 'Features' > 'Implement'
2. Check "AUTO SECTION CONTROL" is enabled.

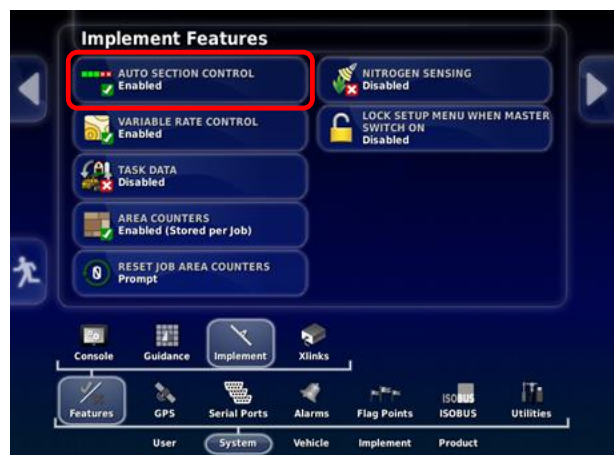

UK847-060.PNG

### 2.4.3 GPS Receiver and Serial port

1. Select 'System Settings' > 'GPS' > 'Receiver'
2. Check "GPS RECEIVER" is set to "Other"



UK847-070.PNG

3. Select 'System Settings' > 'Serial Ports'
4. Set "GPS RECEIVER COM" to "1"



UK847-080.PNG

### 2.4.4 Universal terminal softkey layout

1. Select 'System Settings' > 'ISOBUS' > 'UT'.
2. Set "SOFT KEYS PER COLUMN" to "5".
3. Set "SOFT KEY LOCATION" to "Right + Left".
4. Set "WORKING KEY LOCATION" to "Hidden".

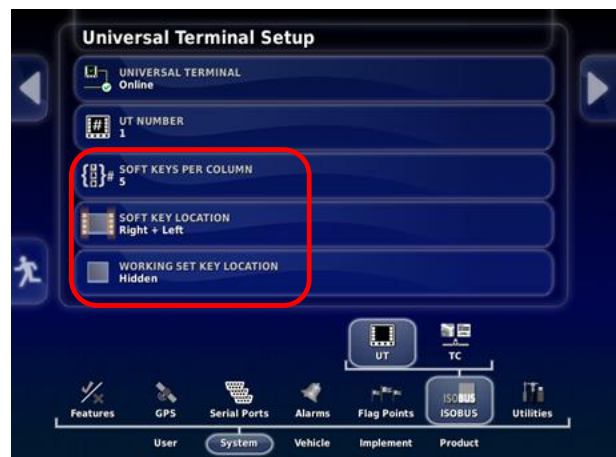

UK847-090.PNG

## 2.4.5 Implement setup

1. Select 'Implement' > 'New'.
2. Select the image that represents a trailed machine.
3. Enter a new name for the implement type



UK847-100.PNG



UK847-110.PNG

4. Set "IMPLEMENT CONTROL" to "Section Control Only".
5. Set "ECU TYPE" to "ISOBUS".

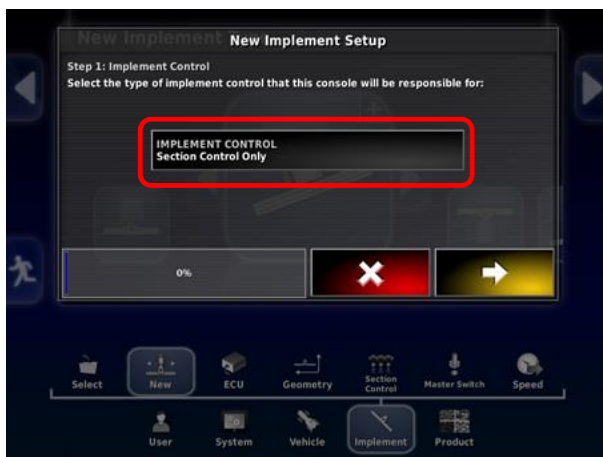

UK847-120.PNG



UK847-130.PNG

6. Set "IMPLEMENT FUNCTION" to "Spreader".
7. Set "ECU ASSIGNMENT" to "RDS Apollo".

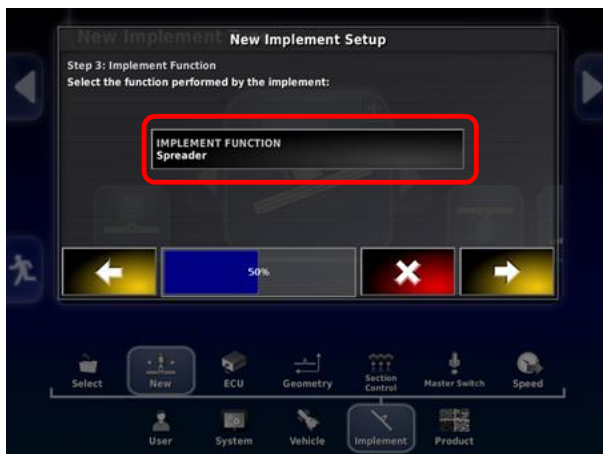

UK847-140.PNG

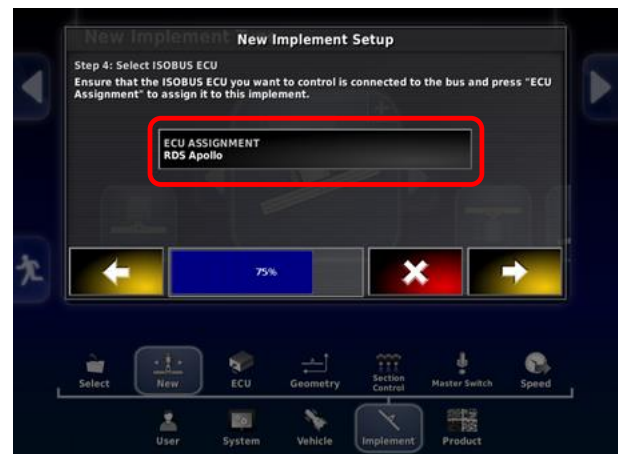

UK847-150.PNG

8. Press  to confirm and save the implement settings.
9. Select 'Implement' > 'ECU'. Now that we have set up the implement this screen provides a summary, and you should see the ECU name as "RDS Apollo" in the table. If not then press "REFRESH ECU SETTINGS" to trigger the ECU to talk to the terminal.



UK847-160.PNG

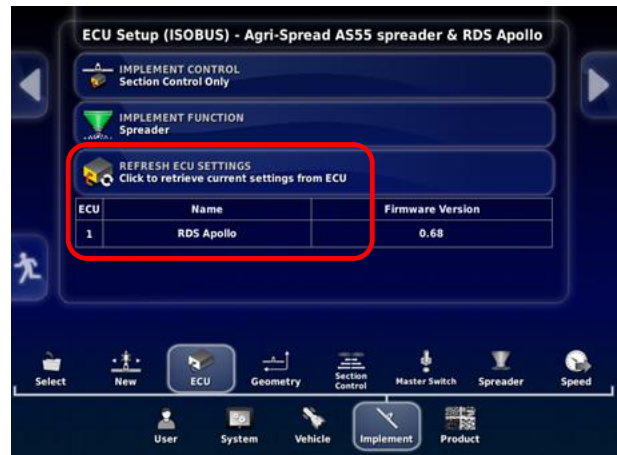

UK847-170.PNG

## 2.4.6 Master Switch

1. Select "Implement" > "Master Switch".
2. Set "MASTER SWITCH" to "Virtual".

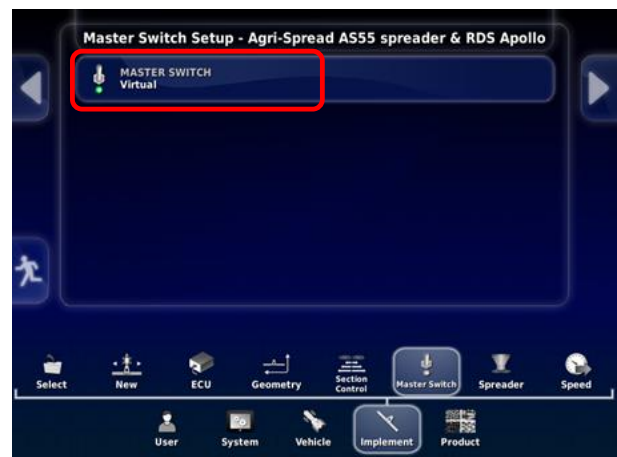

UK847-180.PNG

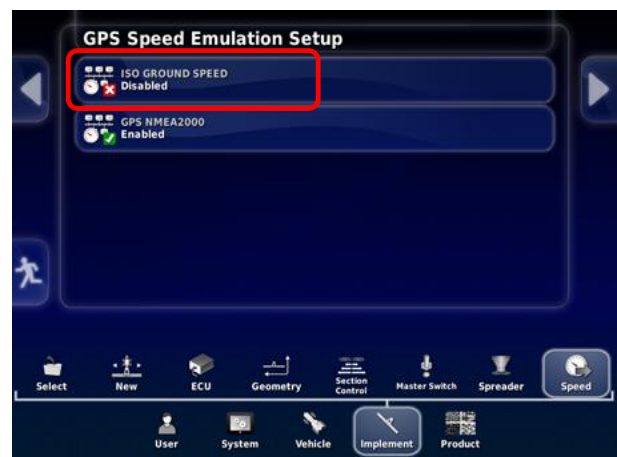

## 2.4.7 Forward Speed Setup

1. Select "Implement" > "Speed".
2. Set "ISO GROUND SPEED" to "Disabled".



UK847-190.PNG

## 2.5 Region settings

Touching  on the Operation screen accesses the Setup screen. Touching  returns to the Operation screen

### 2.5.1 Language set up

The language displayed on the console may be changed if required and decimal separators may be represented by a period or a comma.

1. Select “User” > “Region” > “Language”.
2. Use the scroll bar, or slide a finger down the list, to see more languages. Confirm the selection. The console will restart.

*Note:* The language may also be changed on the warning screen at startup by selecting .

3. A decimal point may be represented by a period (.) or a comma (,).

### 2.5.2 Time/ date set up

The date information is used on the console for job start and end dates, as shown on job reports. The current date is supplied from the GPS signal.

*Note:* Both time and date will not work if there is no GPS signal.



The current date and time can be displayed on the Operation screen by selecting the Topcon icon in the top left of the display (or shown on the dashboard).

1. Select “User” > “Region” > “Time/Date”.

*Note:* Current time does not change automatically for daylight saving.

### 2.5.3 Units setup

The measurement system is set from the X25 setup menu, however the units (e.g. kg/ha, tonnes/ha) are set from the Apollo setup menu.

1. Select “User” > “Region” > “Units”
2. Select the measurement system (metric or imperial).
3. Exit the X25 setup menu and start the Apollo II application.
4. Press  to cycle to the ‘Main Menu’ and press .



UK847-260.PNG

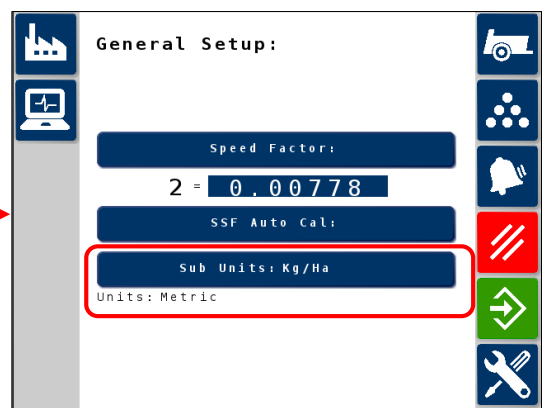

UK847-400.PNG

5. Select the units and press  to confirm.



### 3. Apollo II Operation

#### 3.1 Loading the application

If the Apollo II application was running when the console was last shut down, then the console will automatically default to the Apollo II operating screen on startup. Otherwise, swipe up or down the navigation bar if necessary and select the ISOBUS UT icon



There will be a short delay while the application data is uploaded from the implement ECU, after which a **mini-view** of the application is displayed.

Touch  or swipe the mini-view from left to right to maximise the application window.



UK847-020.PNG

#### 3.2 Universal Terminal window

The Apollo application is displayed in the Universal Terminal (UT) window. The Apollo control keys are those within the UT window.

**NOTE:** The Apollo control key locations are configurable from the setup menu. If you wish to change the configuration from that shown then please refer to section 2.4.4 – “Universal terminal softkey layout”.

You will notice that the toolbar on the right side of the X25 Operation screen has changed from the guidance toolbar. You can generally ignore these keys (unless perhaps you have other ISOBUS applications loaded).

Use the navigation bar on the left side of the X25 Operation screen to access other parts of the system while the Apollo application is running (e.g. guidance), and to return to the Apollo screen (ref. section 2.2.1 – Navigation bar).

Master switch (spreader)

Navigation bar to access other parts of the system

Setup menu

These keys are not required to control the Apollo application.

Note: The ‘DEL’ key is used to delete the application. If accidentally deleted, don’t panic! The application must simply be uploaded from the implement ECU again (3.1).

Master switch (coverage)

Dashboard UK847-030.PNG

**NOTE:** The “dashboard” display along the bottom of the screen is user-configurable from the Setup menu, to display only the information that you require.

### 3.3 Apollo primary screen pages

There are 3 primary screen pages for Apollo. Press  to cycle between the primary screen pages – **Main**, **Totals**, and **Spreader settings**.

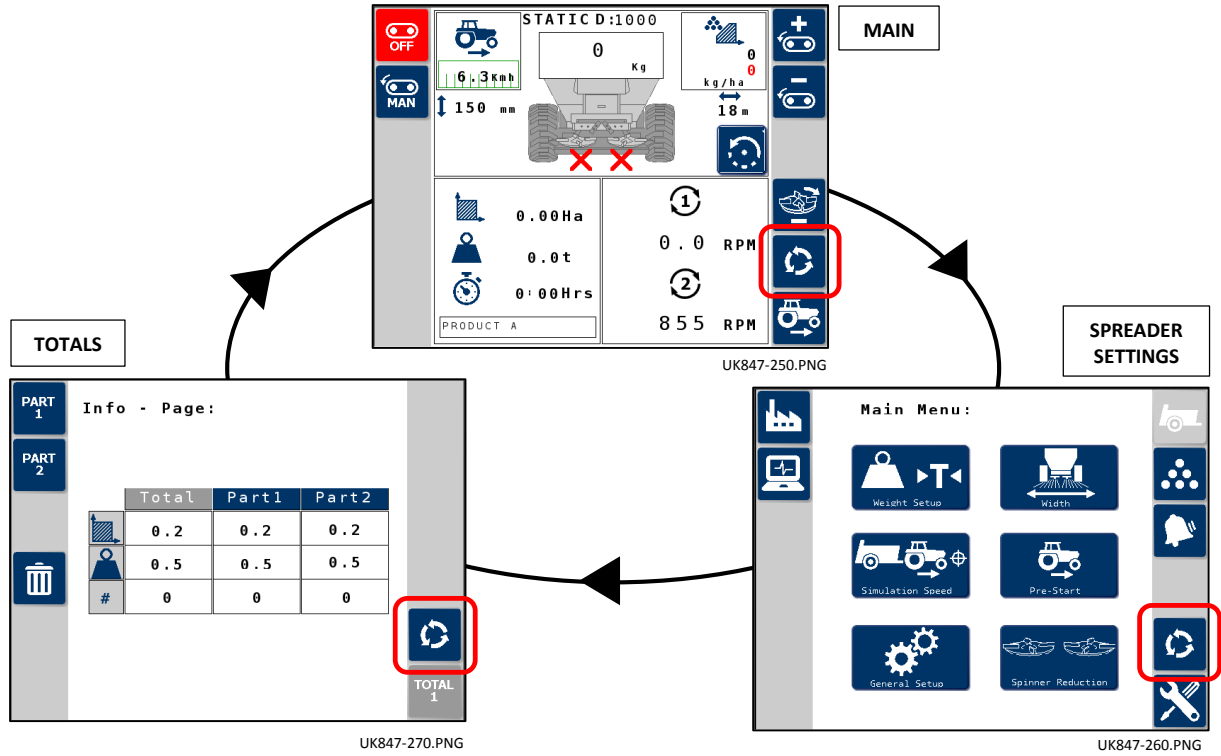

**NOTE:** From any sub-menu, press the  key (repeatedly as required) to return to the primary screen page.

### 3.4 The Main Operating screen

The main screen appearance can differ depending how the software is configured, and which function is selected.

#### MAIN Job Information Display

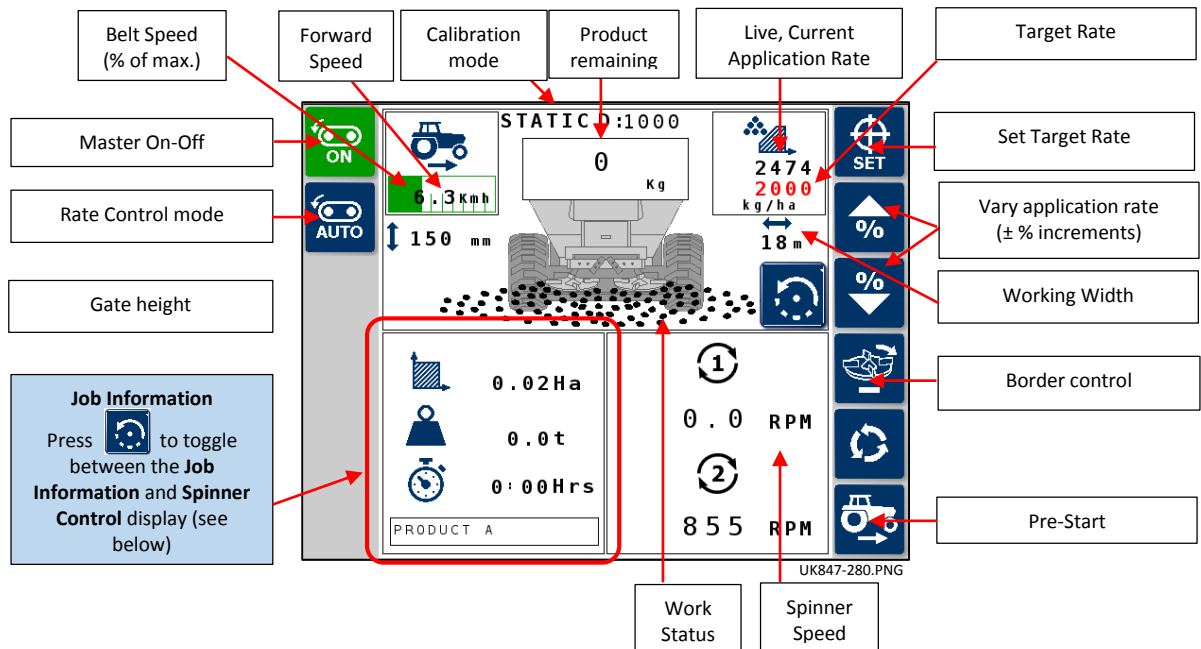

(without "Auxiliary Function" / Gate Height control features enabled).



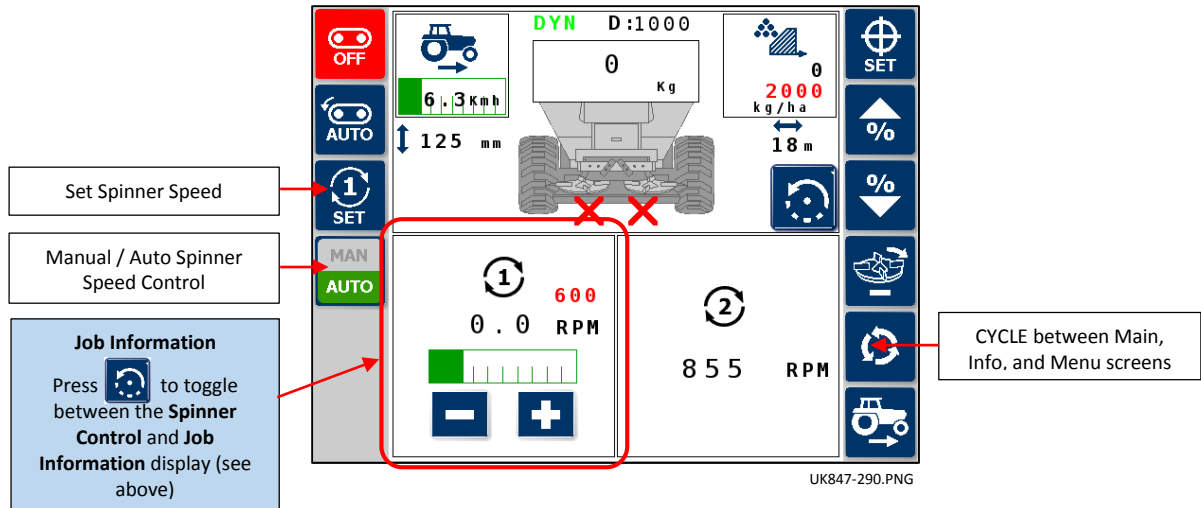

### MAIN Spinner Speed Control Display





#### 3.4.1 Spreader Master Switch Status



The spreader is switched on/off by the  /  softkeys.

**NOTE:** This does not simultaneously activate / deactivate coverage as indicated on the guidance screen. Coverage is independently activated / deactivated using the  /  keys (ref. 2.2.4).

#### 3.4.2 Auto / Manual Spinner speed control

The 'Job Information' and 'Spinner Speed Control' features share the same portion of the screen. Press  to switch between the two functions.

Press  to toggle between automatic and manual control of spinner speed.

In automatic mode, press  to enter the spinner RPM  and press  to confirm.

In manual mode, the spinner speed can be adjusted on-the-go using the '-' and '+' keys.

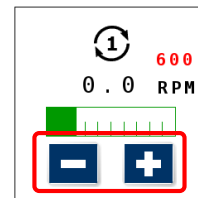

**NOTE:** Please refer to the implement manual to establish the correct Spinner RPM for the product / desired spread width.

### 3.4.3 Automatic rate control mode and setting a target rate

Press  /  and to toggle between automatic and manual rate control.

Press  to enter the target rate and press to confirm.

The floor speed is automatically adjusted to maintain the correct rate based on the forward speed and working width.

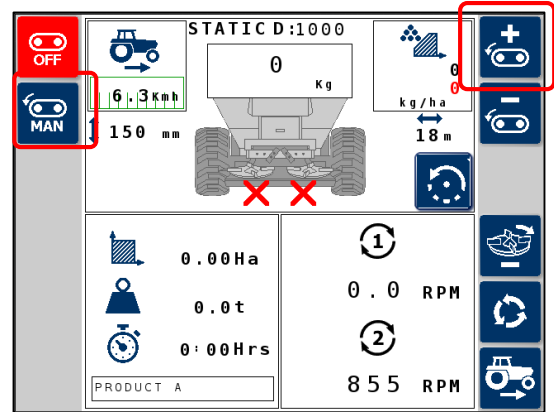



UK847-300.PNG

### 3.4.4 Varying the application rate in auto mode



Press  to temporarily adjust the rate above or below the target (base) rate by percentage increments.



When the rate is set "off-target", the  key changes to .

Press  to return to the target rate.

### 3.4.5 Manual rate control mode

The floor speed is manually controlled using  .

The floor speed is not proportional to forward speed. Therefore, to keep matching a target rate, you must manually adjust the floor speed in tandem with changing forward speed.

Manual mode is commonly used to run the floor belt while the spreader is stationary (for example to clear out the remaining contents)

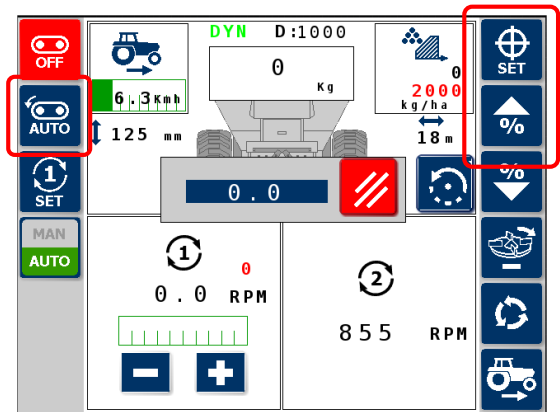

UK847-250.PNG

### 3.4.6 Pre-Start



The Pre-Start function is used to start the floor moving when there is no forward speed. The benefits of this are to ensure that there is good coverage at the start of each bout and to ensure that irrespective of how the product has been loaded, the spreader does not have to start moving until a suitable amount of product has reached the spinners.

If configured to 'AUTO' mode (4.4), the Pre-Start function is automatically triggered when the spreader is switched into work. This prevents having to push the button at the start of each load.

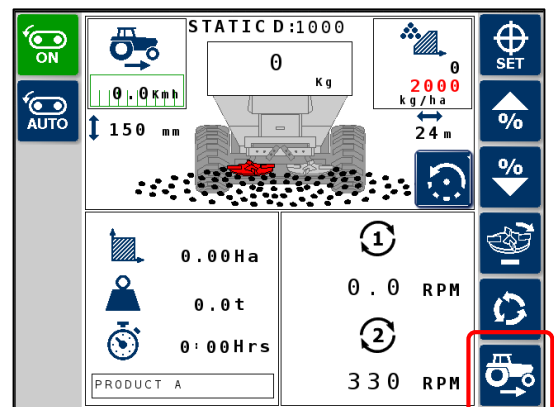

UK847-310.PNG

If configured to 'MAN' mode - the Pre-Start function is activated manually by pressing  .

The product automatically moves towards the spinners.

Once the spread pattern is observed, then start to drive forwards.

NOTE: This is not always necessary on a fertilizer spreader due to product being readily available at the gate.

### 3.4.7 Border reduction



If specified as an option on the spreader, by means of a hydraulic diverter valve either the left-hand spinner or the righthand spinner RPM (depending on the hydraulic installation) can be slowed down to reduce the spread width when traversing the field boundary.

Boundary reduction indicator

Press  to reduce the specified spinner side by the pre-programmed percentage.

The instrument will beep every 15 seconds to remind the operator that this function is enabled, and the spinner icon on the main page will become red.

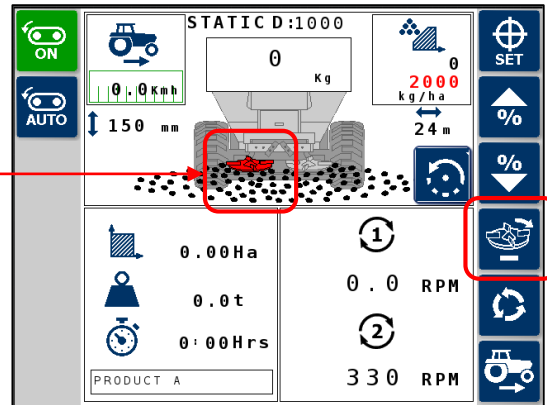

UK847-310.PNG

### 3.5 Totals Screen

Records the grand total and Part Totals 1 and 2 of Area, Weight, Time and Date of last reset, No. of Loads.

Info - Page:

	Total	Part1	Part2
	0.2	0.2	0.2
	0.5	0.5	0.5
	0	0	0

Part Total 1 → PART 1

Part Total 2 → PART 2

Reset selected Total →

→ CYCLE Main, Info, Menu

→ Grand Total

UK847-320.PNG

NOTE: Job totals cannot be logged to files.

## 3.6 Add weight / Tare

The main screen displays the current weight remaining in the hopper (a theoretical calculation if volumetric calibration is in effect, or for dynamic calibration it is the actual weight measurement from loadcells). The weight setup screens vary depending whether the system has loadcells or not.

### 3.6.1 Machines with loadcells

On machines with loadcells, the hopper contents display will automatically refresh with the current weight as product is loaded. In order to maintain correct angle compensation, only perform the tare with the spreader on level ground.

#### Set tare

Press  to cycle to the 'Main Menu' and press .

Press "Tare Calibration". The weight can be tared either when the hopper is empty, or if it contains a known weight. Simply follow the screen prompts.

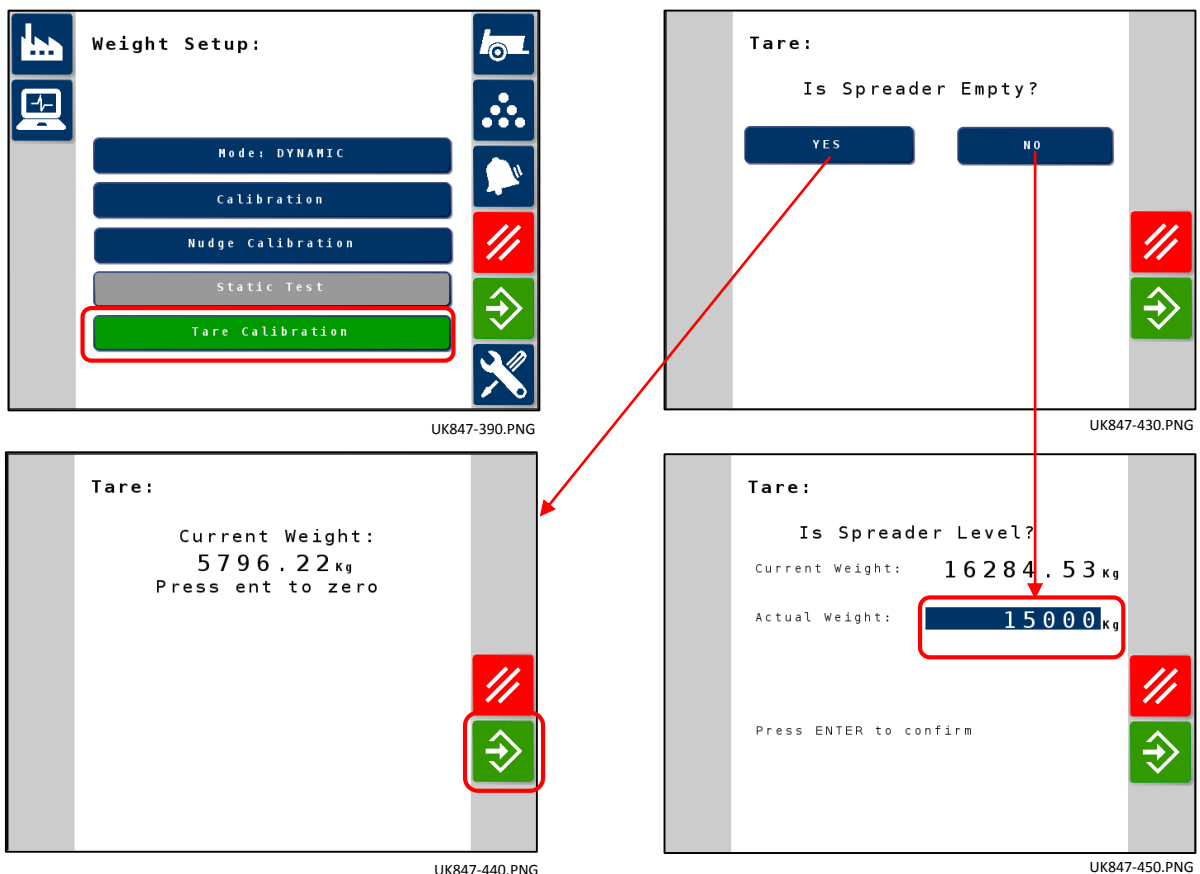

### 3.6.2 Machines without loadcells

1. Refill the hopper with the desired load.
2. From the "Weight Setup" menu, press "Add Weight / Tare".

**MAX:** The full hopper weight. Confirm that 'MAX' corresponds to the hopper maximum capacity, and adjust if necessary.

If loading the hopper to capacity, then simply press 'OK' to reset to full.

**NOW:** The current (theoretical) weight remaining in the hopper.

**TO ADD:** The weight required to replenish the hopper ('MAX' – 'NOW').

When this weight has been added to the hopper, press 'OK' to confirm it has been loaded. The 'TOO ADD' value is added to the 'NOW' total, and 'TOO ADD' is recalculated.

## 4 Job management and variable rate control (VRC)

### 4.1 Field setup



The first steps when beginning a job are to set client, farm, field, boundaries, exclusion zones and flag points. The console will store the field information so that, once set up, the field details can be recalled for other jobs in the same field.

**NOTE:** This section does not describe all features and functions. If necessary, then please refer to the X25 Operator's manual for further information.

#### 4.1.1 Creating a new client / farm / field

Drive to the field and follow the steps to set up a field and identify its features.

**NOTE:** The vehicle must be in or near the field for boundaries and related information to appear on the screen.

1. Select **Field Menu**  / **New Field**  .





**NOTE:** Default file names are provided when naming options appear. It is highly recommended that the operator names items in a thoughtful and structured way to allow easy use in future seasons.

2. Select **CLIENT NAME**, (or select an existing client if some have already been set up).
3. Select **New**, enter a name and confirm.
4. Select **FARM NAME**, (or select an existing farm name if some have already been set up).
5. Enter a name and confirm.
6. Select **FIELD NAME**, enter a name and confirm.
7. Completing this section selects the new field.

**NOTE:** To change any of these settings after they have been confirmed, refer to Inventory Manager.

#### 4.1.2 Selecting a client / farm / field

**NOTE:** The vehicle must be in or near the field for boundaries and related information to appear on the screen.



1. Select **Field Menu**  / **Select Field**  .
2. Select the required client, farm and field, then confirm.
3. To import field information from a USB, select **USB**  .
4. To select the nearest field, select **Nearest Field**  . The current GPS position is used. This will only work if the nearby fields have boundaries created.
5. Confirm field selections.

**NOTE:** To change any of these settings after they have been confirmed, refer to Inventory Manager.

#### 4.1.3 Setting a new boundary

If required, it is possible to create multiple boundaries within a field. They may be created by driving around the boundary created from coverage, or created from shapefiles. The interior of a created boundary defaults to a work region, however, any boundaries created within that boundary, default to an excluded region (shown as greyed out). These properties may be edited.

Setting the boundary establishes the perimeter of the field (or a section of a field). Boundaries may overlap. A boundary recording offset may be specified to control where the boundary is recorded in relation to the vehicle. This accounts for fences and other obstacles that do not allow the vehicle to drive exactly on the boundary. Once the offset is entered, the vehicle must be driven around the boundary of the field.

1. Drive the vehicle to the edge of the field.
2. Select **Field Menu**  / **Boundary Offset**  .

**'Recording Offset':** Positions the offset on the left or right side of the implement.

**'Additional Offset':** Enter a positive value to extend the offset beyond the edge of the implement. A negative value positions the offset within the implement extents.

**'Recording Position':** Select to record the boundary from the front or rear of the implement, or from the position of the vehicle.

*NOTE: An implement needs to have been established during setup, but the actual implement does not need to be physically attached to the vehicle.*

3. Select **Record Field Boundary**  .

4. Drive the vehicle around the boundary of the field. A blue line will display the boundary being recorded, taking into account any offset.

Select **Pause**  to pause recording. This is useful if an obstacle prevents driving on the boundary. The icon will change to show the record option.

Select **Record**  to resume. The boundary will record a straight line between the point recording was paused and the point recording was resumed. Note that boundary recording may be automatically paused if the master switch is turned off.

5. As the vehicle approaches the start point, select **Complete Field Boundary Recording**  to automatically complete the boundary.

6. Repeat the procedure for more boundaries, if required.

*Please refer to X25 Operator's manual for,*

- *creating a boundary from coverage / shapefile*
- *editing / removing a boundary*
- *Setting up a working headland*
- *Setting flag points*

#### 4.1.4 Unloading a field

The **Unload field**  option may be used to exit from a field and its associated flag points, boundaries etc. This prevents new coverage being added to the field if the vehicle has been moved to a new field but the operator has neglected to create a new field / job.

If this option is not used, when the vehicle has moved more than 15 km away from the current field, the message "**The active field is more than 15 km away and has been deactivated and its data unloaded.**" is displayed, and the field is unloaded automatically.

*NOTE: The console will no longer restart when it has travelled too far from the current field.*



## 4.2 Job Setup



The Job Menu selects or sets up specific job information associated with the chosen field. Using this menu, the job information is stored and activity can be recorded and reported.

### 4.2.1 Creating a new job

1. To set up a new job, select **Job Menu** / **Create New Job** .
2. Select **JOB NAME**.
3. Enter a name and confirm.

**NOTE:** *Default file names are provided when naming options appear. It is highly recommended that the operator names items in a thoughtful and structured way to allow easy use in future seasons.*

4. Confirm the new job.

**NOTE:** *Please refer to X25 Operator's manual for setting up job regions.*

### 4.2.2 Selecting an existing job

Job information can be recorded, stored and transferred for later access. Drive to the field and follow the steps to choose an existing job.

1. Before selecting an existing job, ensure the correct field is selected.
2. To choose from a list of existing jobs, select **Job Menu** / **Select Job** .
3. Select the job and confirm.

**NOTE:** *Changing the client, farm or field at the top of the 'Select Job' window allows importing of a job from a neighboring field. This can be useful in order to reuse common information stored within the job, such as weather observations, crop information or product application notes.*

*The coverage should be cleared manually before starting the new job. The same implement that was used to create the job must be selected to load an existing job.*

*Please refer to X25 Operator's manual for recording job details or exporting a job report.*

### 4.2.3 Clearing a job

This action will remove any coverage information on the screen and delete job data that has been recorded on the current job. It does not affect field information or guidelines set for the field.

1. Select **Job Menu** / **Clear Job Data** .

The following message appears.

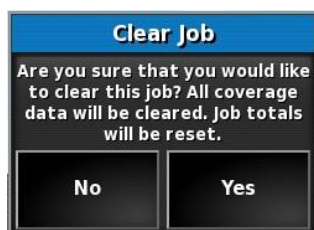

2. Select **'Yes'** to clear the data or **'No'** to keep the data.

**NOTE:** *To delete farms or fields or previously created job data, refer to Inventory Manager.*

## 4.3 Using variable rate control (VRC)

Before use, Variable Rate Control (VRC) must be set up with a controller and must be enabled on the Setup screen (**System > Features > Implement**).

Select  to enable or disable the VRC Map display on the guidance screen.





### 4.3.1 Loading a Variable Rate Map

There are three ways to perform VRC:

- Importing prescription maps (shapefiles and ISO XML files) into created jobs using the VRC import wizard.
- Using real-time sensor data from nitrogen sensors mounted on the tractor (for example: Topcon CropSpec).
- Using Task Data based prescription maps.

The following instructions describe the first two methods. If using task data, refer to AGA4084 Guidance Manual.

Both shapefiles (.shp) and ISO XML files (.xml) may be imported into created jobs. Note that only the prescription map portion of the data is used if .xml files are imported.

1. Select a client / farm / field.
2. Create a new job.
3. Select **Job Menu**  / **Configure Variable Rate Control** .
4. Select 'next' (  ) at step 1 of the VRC Configuration wizard.
5. Select the rate source(s) for the VRC and select **next** (  ). The possible options are:
  - Shapefiles
  - ISO XML
  - CropSpec (if enabled)

Note that shapefiles and ISO XML cannot be used at the same time. However CropSpec can be used in conjunction with shapefiles or ISO XML.

**If Shapefiles or ISO XML are selected at step 2**, all maps previously imported to the current field are displayed so that previously used maps can be recalled.



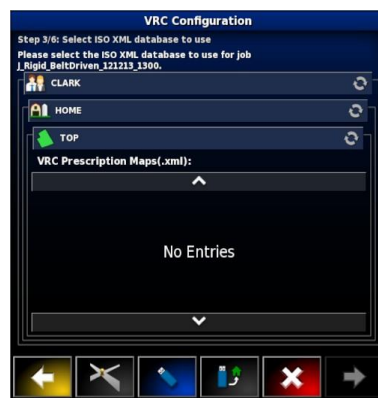

- If the desired maps are not already on the console, insert a USB with prescription maps.
- Select the USB icon (  ) at base of the screen. The window background turns blue to indicate you are viewing the USB file list.

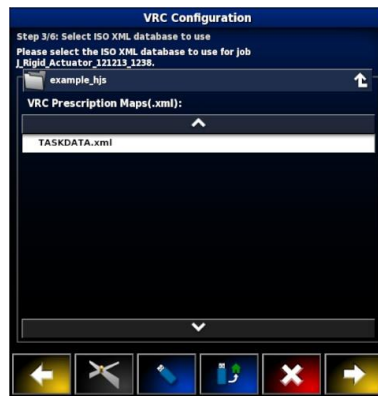

- Select the USB home icon (  ) to view the root of the USB file structure. Files and folders on the USB root are displayed.

- Select a folder to open it. Find the required file and select it. It will display as white and **next** (  ) is now enabled. Note that multiple files may be selected.



- Select **'next'** (  ) .
6. **If ISO XML was selected in step 2**, select the task that you wish to run. The file may have several tasks listed. Select the task that matches the implement that is hooked up.
  7. Select **'next'** (  ). Source and Attributes must now be assigned to channels.
    - **Channel:** The tank or bin that is being controlled.
    - **Source:** The source of the prescription map for that channel. The list of files that were selected earlier on will appear here or you can also select a live source like CropSpec or Yara.
    - **Attribute:** One of the properties in the shape file or ISOXML file or the sensor output from CropSpec. The shape file may have multiple attributes to define the rates for more than one tank so this allows operator to map the prescription to the appropriate tank.
    - **Rescale:** This column defaults to 1, which means that the prescription defined in the source will be used directly. However, depending on weather conditions, the operator may choose to increase or decrease the rate of application. This allows a uniform increase for all defined rates. For example, a rescale of 1.1 will apply 110 percent of the rate defined in the source.
    - **Default:** Defines the rate to use if the source doesn't specify a rate for that region of the paddock.
  8. Select **'next'** (  ).
  9. On the final step, you must confirm the setup. This cannot be changed for the job, so ensure it is correct before continuing.
- Select **'Back'** (  ) to change the configuration or **'OK'** to confirm.

The map is displayed. If it does not display, ensure you are in close proximity geographically to the map's location.

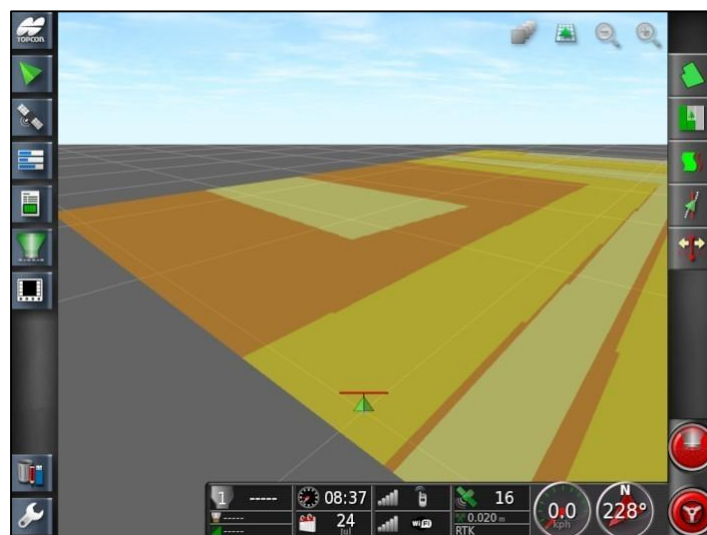

## 4.4 Auto section control (ASC)



Auto section control is available when the implement and ECU have been set up and Auto Section Control has been enabled in the Setup screen (**System > Features > Implement**).

1. Select **Auto Section Control** (  ).

The Auto Section Control mini-view opens.

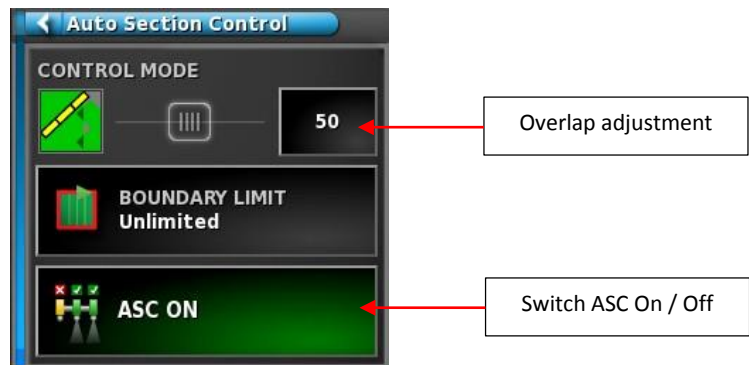





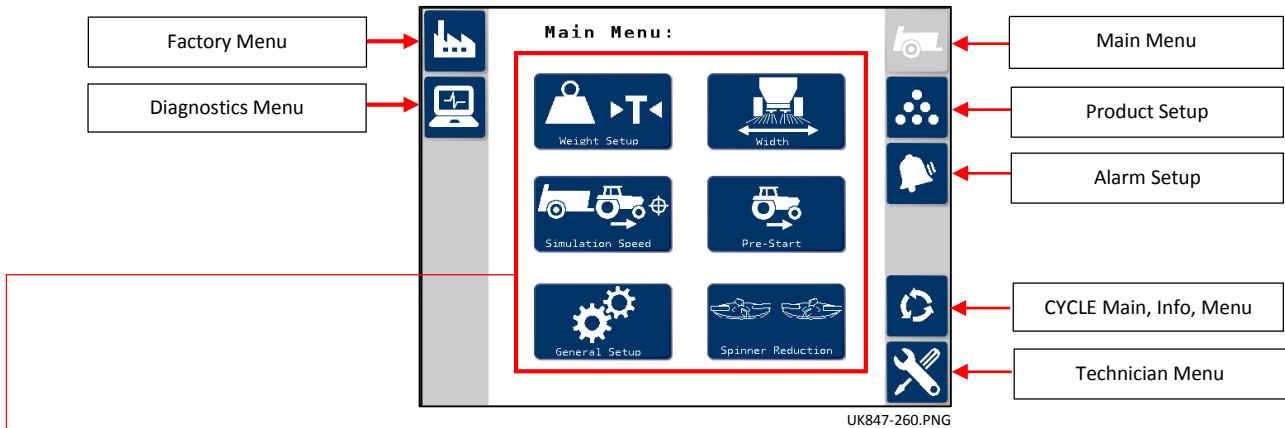

- **Control mode:** Use the slider or number keypad to set to avoid overlap (0) or avoid gaps (100). If avoid overlap is chosen, there may be some spaces where product is not applied. If avoid gaps is chosen, some overlap of application is likely near boundaries. The default (50) is a compromise.
- **Boundary limit:** Sets which type of boundary limit will turn off spraying when using auto section control.  
**Field Boundary** and **Headland** are defined using the Field menu (  ) on the Operation screen. Refer to the Guidance and Auto Steering Operator Manual for more information on these. **Safety Zone** reduces width of spreading by half a swath width from the boundary to prevent over application.
- **ASC on/off:** Turn auto section control on/off.



## 5. Apollo II Setup

### 5.1 'Main Menu' Screen



The following is a summary of the more frequently accessed settings. You should not need to enter the Technician or Factory menus in normal use.

Sub-Menu	Setting	Options	Notes	Ref.
<b>Weight Setup</b> (with loadcells) 	Mode	DYN	Select between Dynamic, Static or Manual calibration modes	
		STATIC		
		MAN		
	Calibration		(No function)	
Static Test		Start the static test routine (Static mode)		
Tare		Tare the load cells when spreader is empty		
<b>Weight Setup</b> (without loadcells) 	Mode	AUTO	Select Manual or Automatic volumetric calibration mode.	
		MAN		
	Calibration		Starts the volumetric calibration routine	
	Calibration Nudge		The existing cal factor can be nudged.	
	Add Weight / Tare	ADD	Set maximum weight in hopper	
NOW		Set current weight in hopper		
TO ADD		Press ENTER to reset to FULL		
<b>Width Setup</b> 			Set full working width	
<b>Simulation Speed</b> 	Set Speed		The simulated speed is used for testing the machine in the factory or if there is a problem with the normal forward speed signal	
	ON/OFF		Enable the simulated speed	
<b>Pre-Start</b> 	Pre-Start Time		Duration that floor runs before stopping if spreader remains stationary	
	Pre-Start Mode	AUTO	Pre-Start function begins automatically when spreader is switched into work.	
MAN		Pre-Start function is selected manually.		
<b>General Setup</b> 	Speed Factor	0 = 1	Magnetic sensor : 1 pulse per rev.	
		1 = 2	Magnetic sensor : 2 pulses per rev.	
		2 = 0.0078	RDS Radar Sensor : 0.0078m per pulse	
		3 = GPS	GPS receiver : NMEA VTG message	
	Units	METRIC	Metric only	
	SSF Auto Cal		Start the speed sensor auto-calibration routine.	
<b>Spinner Reduction</b> 	Border Reduction		Reduce the spinner RPM when applying along a boundary	

Press  to return to the previous screen or  to confirm an entry.

## 5.2 Product setup

### 5.2.1 Select a product

Press  to cycle to the 'Main Menu' screen and press .

The system can store 10 different products with customizable names.

Press  and then  or  to select the product.

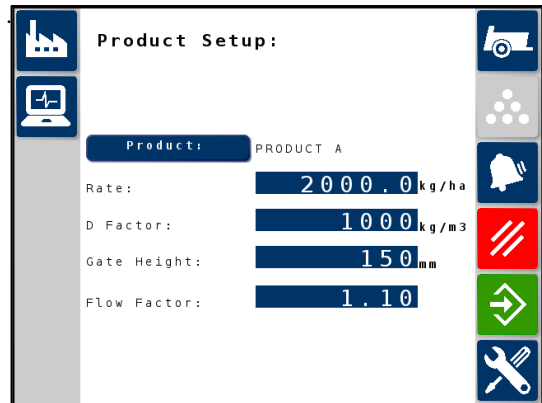

UK847-330.PNG

### 5.2.2 Other product settings

#### Edit a product name

Touching on the product name will display the keyboard to edit the name.

#### Product density ("D factor")

"D Factor" is the product density. Note the units when entering the density.

#### Gate height

The gate height and maximum forward speed are theoretically calculated as a result of the volumetric calibration routine via 'Main Menu' > 'Weight Setup' > 'Calibration'.

#### Flow Factor

The Flow Factor accounts for any product flow inconsistencies that may come from prilled or low friction products. It can be established either by carrying out a calibration nudge after spreading a certain amount of product (6.3), or following a specific calibration routine (ref. section 6.2.1).

## 5.3 Alarm setup

Press  to cycle to the 'Main Menu' screen and press .



You can set the system to alarm in the following conditions,

- Spinners (RPM 1 / 2) too slow / too fast
- "Low Level" - Hopper level low
- "Beacon Weight" - Hopper maximum load (activates a warning beacon output if maximum weight exceeded). Only applicable if loadcells are fitted.

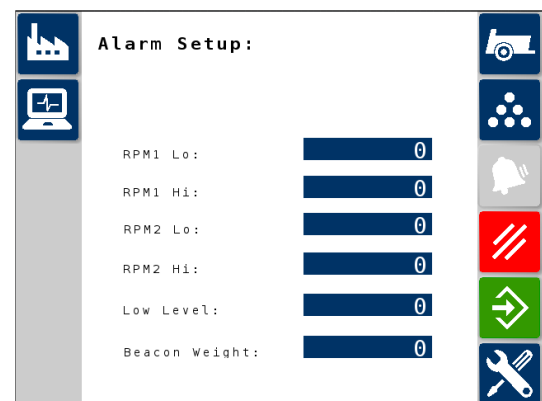
**NOTE:** When set to zero, functions are disabled.



## 5.4 Pre-Start setup

Press  to cycle to the 'Main Menu' and press  .

**Pre-Start time:**

This is the duration that the Pre-Start will run for before stopping the floor if there is no forward speed movement. This should be long enough to ensure that product is being spread but also so that there is a smooth transition between pre-start and starting to move forward. An average pre-start time would be around 8-10 seconds.

Default = 8 sec

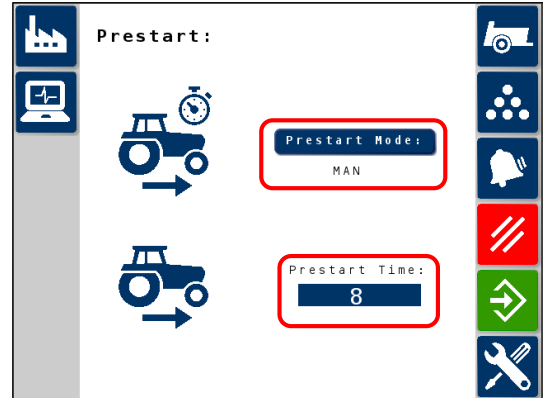

UK847-420.PNG

 **Pre-Start Mode:**

'**AUTO**' mode – the Pre-Start function is automatically triggered when the spreader is switched into work. This prevents having to push the button at the start of each load.

'**MAN**' mode - the Pre-Start function is activated manually by pressing  .

Default = MAN

## 5.5 Border reduction setup

Press  to cycle to the 'Main Menu' and press  .

The spinner reduced speed is set as a percentage of the full speed. The reduction must be established by trial and error to establish the desired spread pattern.

'Reduction Left' or 'Reduction Right' is determined by the hydraulic installation.

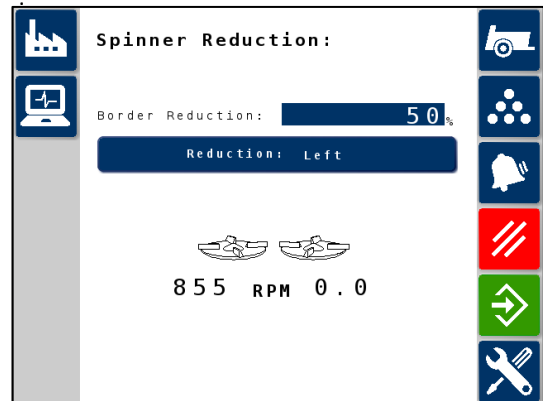

UK847-370.PNG

## 5.6 Width Setup

Press  to cycle to the 'Main Menu' and press  .

This sets the full working width of the spreader.

**NOTE:** Please refer to the implement manual to establish the correct spinner RPM for the product / desired spread width.

### Offsets

These are the dimensions from the GPS receiver location to where the product is applied, as part of guidance setup.

They do not normally need to be changed.

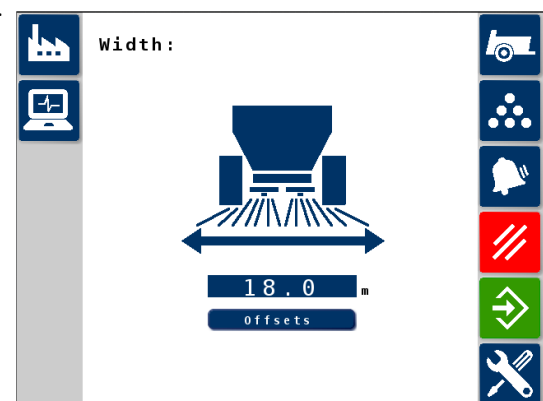

UK847-380.PNG

## 5.7 Forward Speed Setup

### 5.7.1 Forward Speed Input

Press  to cycle to the 'Main Menu' and press .

There are 4 preset options for the Forward Speed signal,

- (0) : Magnetic sensor (1 pulse per rev)
- (1) : Magnetic sensor (2 pulses per rev)
- (2) : Radar sensor (0.00778 metres per pulse)
- (3) : GPS (NMEA VTG message)

With the exception of option (3), the factors can be manually edited if required.

However if options (0), (1) or (2) are selected, it is recommended to perform an 'Autocal' routine.

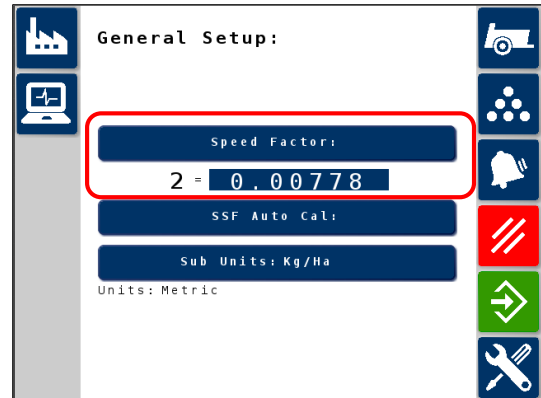

UK847-400.PNG

### 5.7.2 SSF Autocal

The Speed Sensor Factor ("SSF") is the distance travelled forward in the time between two pulses from the forward speed sensor. In the case of magnetic sensor options (1) and (2), this could be calculated based on the nominal tyre diameter or rolling distance and then entered manually. However this does not take into account wheel slip, compaction, or tyre deformation under practical operating conditions.

Mark a set distance of 100 metres by suitable means. The surface should be representative of the average field conditions (i.e. not a paved surface). Position the vehicle with the first marker level with a suitable reference point on the vehicle.

Select "SSF Auto Cal" and then follow the screen instructions.

Stop the vehicle when the second marker lines up with the pre-determined reference point on the vehicle and press to end the "Auto Cal" procedure. The Speed Sensor Factor is automatically re-calculated and stored in memory.

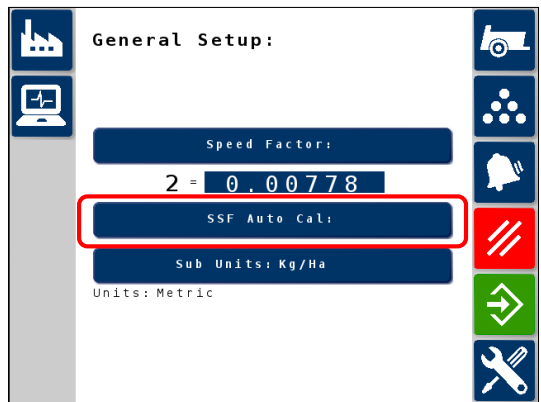

UK847-400.PNG

**NOTE:** If you overrun the marker, do not simply reverse - repeat the "Auto Cal" procedure from the beginning.

### 5.7.3 Simulated Speed

Press  to cycle to the 'Main Menu' and press .

If for whatever reason, the speed sensor is not providing a signal, you can set a simulated speed to continue operation.

Enter the desired speed (km/hr) and switch the simulation ON.

Press  to start the simulation.

**NOTE:** You must match your actual forward speed to the simulated speed as best you can, other the system will under-apply if you travel too quickly, or over-apply if you travel too slowly.

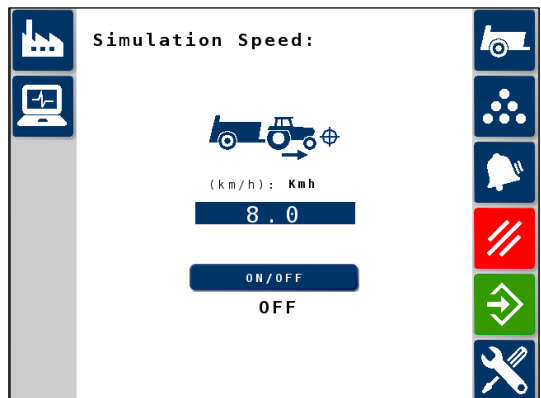

UK847-410.PNG



## 6. Product Calibration



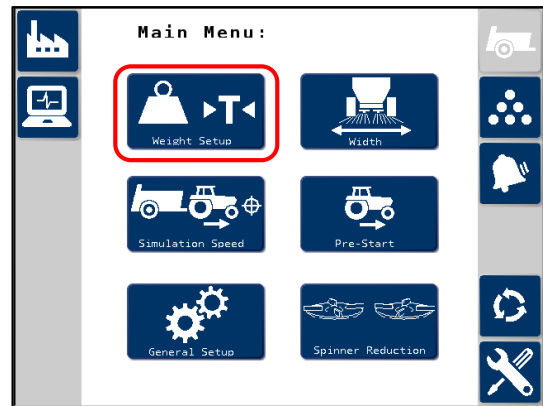

Product calibration is performed via the “Weight Setup” menu.

Press  to cycle to the ‘Main Menu’ and press  .



UK847-260.PNG

The following table summarises the options.

Cal Mode Rate control mode	Machines with Loadcells		Without Loadcells
	Dynamic calibration	Static calibration	Volumetric calibration
	The target rate is entered on the main screen. Full automatic mode proportional to forward speed.		
	The floor speed is automatically adjusted to maintain the correct rate based on the forward speed and working width.		
	Continuous, automatic calibration corrections are taking place.	The calibration factor is that established by the last static calibration.	The calibration factor is that established by the last volumetric calibration.
	The rate shown is a live value based on the current floor speed and ‘T’ factor		
	Weight shown is the live weight measured by the loadcells.	Weight shown is theoretical based on the floor speed and gate height	
	The floor speed is manually controlled using  and 		
	The floor speed is not proportional to forward speed. Therefore, to keep matching a target rate, you must manually adjust the floor speed in tandem with changing forward speed. Manual mode is commonly used to run the floor belt while the spreader is stationary (for example to clear out the remaining contents)		
	The calibration factor is that established by the last dynamic correction.	The calibration factor is that established by the last static calibration.	The calibration factor is that established by the last volumetric calibration.
	Loadcell signals are not being used for calibration		N/A
	Weight shown is the live weight measured by the loadcells.	Weight shown is theoretical based on the floor speed and gate height	

## 6.1 Calibration mode (with loadcells)

There are two calibration modes for machines; either,

- Dynamic – constant, automatic re-calibration on-the-move.
- Static – calibration over a set distance.

### 6.1.1 Selecting Dynamic / Static Calibration Mode

From the “Weight Setup” menu, press “Mode”.

Press  /  to change mode.

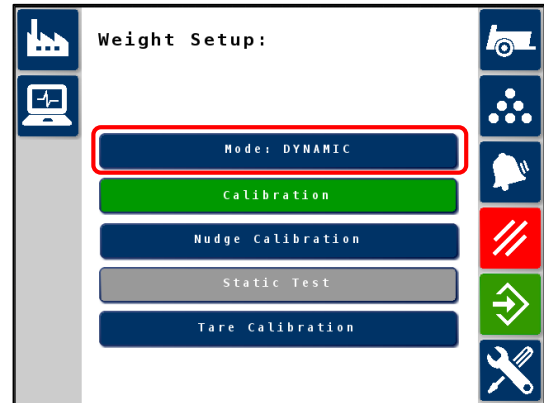

UK847-350.PNG

### 6.1.2 Static mode

The calibration factor is calculated by doing a “Static Test” routine. This factor remains the same throughout subsequent spreading until either manually adjusted, or another static test is done. Static calibration assumes that the product density will be consistent, therefore results may not be as accurate as with dynamic calibration.

From the “Weight Setup” menu, press “Static Test”.

1. While stationary, press ‘OK’ to start the test.
2. The weight in the hopper is measured. The system then calculates the distance that must be driven, based on application rate and spread width set, until the hopper weight decreases to a pre-set threshold.
3. Start spreading until prompted to stop.
4. Press ‘OK’ to measure the weight and calculate the new cal factor, which is then displayed.
5. Press ‘OK’ to confirm, and the ‘ESC’ to return to the Main menu.

### 6.1.3 Dynamic (‘DYN’) mode

The system will normally be operated in Dynamic (‘DYN’) calibration mode. This method of calibration is particularly suited for products with more variable density.

The weight of the product is constantly measured by the loadcells. The amount the actual weight has decreased is compared to the theoretical weight decrease. The Cal. Factor is then adjusted to speed up or slow down the floor speed accordingly. The operator should only have to enter the target rate and working width and all other factors are adjusted in the background to ensure the correct rate is applied.

As dynamic calibration is constantly self-correcting, the calibration routine is there simply to assist in determining the appropriate gate height and to calculate the forward speed range for applying a new product.

## 6.2 Calibration routine (with or without loadcells)

The calibration factor is called the ‘T’ factor. It is the volume of product dispensed per revolution of the floor belt roller. It is calculated as,

Gate height (mm) x Gate width (mm) x belt travel per rev. of the belt roller (mm).

The product density is then used to convert the volume to weight. Volumetric mode is best suited for relatively free-flowing products with a consistent density.

1. Select the product (section 5.2.1).
2. From the “**Weight Setup**” menu, press “**Calibration**”.
3. There then follows a number of screens to enter,
  - required application rate
  - working width
  - density
  - average speed

Based on the information entered, the software recommends a gate height setting. This takes account of the minimum and maximum RPM of the belt roller. The recommended gate height is based on the roller rotating in the middle of its RPM range, so that it allows maximum flexibility to forward speed.

4. You can then confirm the gate height or enter a different gate height if desired.
5. The operating speed range is then displayed based on the above calculations. Press  to continue.

6. If you have not previously done so, then select “**Check Calibration**” to determine the “Flow Factor” for the product (continue to section 6.2.1).

Otherwise select “**Start Spreading**” to end the calibration sequence and return to the main operating screen.

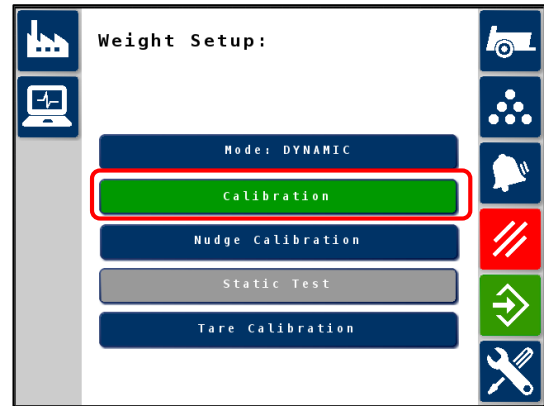

UK847-350.PNG

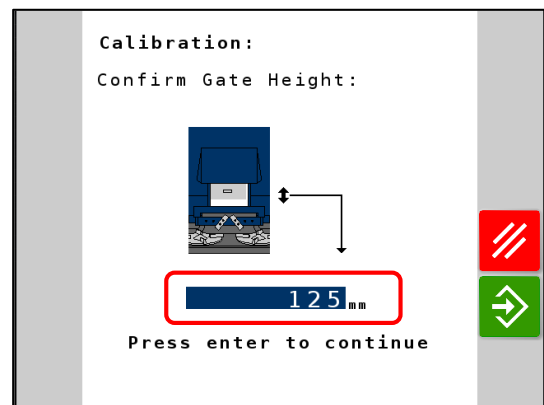

UK847-460.PNG

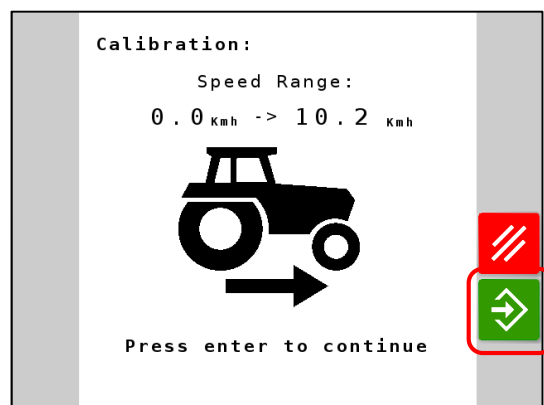

UK847-470.PNG

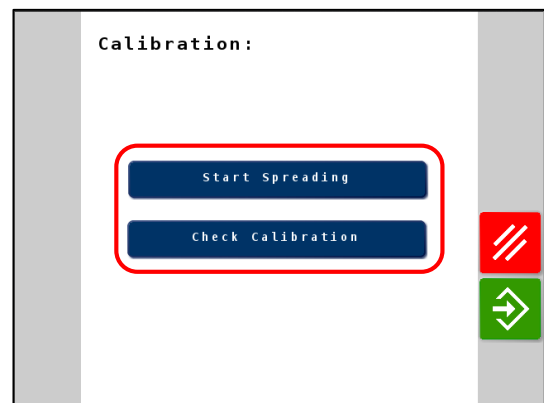

UK847-480.PNG

### 6.2.1 Product Flow Factor – “Check calibration” routine

The Flow Factor accounts for any product flow inconsistencies that may come from prilled or low friction products. In order to achieve accuracy across a complete product range, each product should be tested to enable the system to learn the flow characteristics of that material.

The Flow Factor can be established either by,

- (i) following the “Check Calibration” routine. This routine involves running the floor for a set time period, catching and then weighing the product that is dispensed from the spreader.

**NOTE:** *It is advised if catching the product to be weighed, to select enough product for a minimum of 5Ha depending upon target rate. The system will run the belt for that much product and can then be calibrated once this has been weighed. **The greater the volume of product dispensed for calibration, the greater the accuracy.***

- (ii) carrying out a calibration nudge after spreading a certain amount of product (ref. section 6.3).

7. From the “Weight Setup” menu, press “Calibration”. Follow the product calibration procedure through and then select “Check Calibration”.

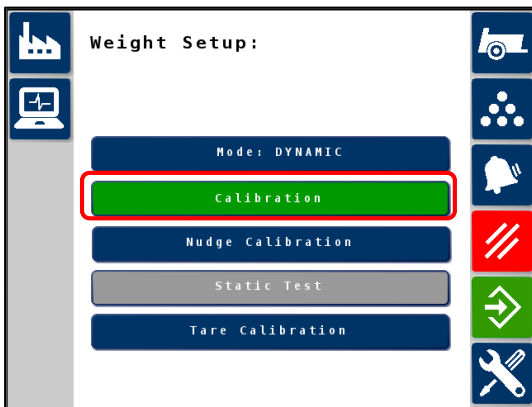



UK847-350.PNG



UK847-480.PNG

8. Enter the weight of product to be caught and weighed for the test.

9. Press  to switch the spreader on.

10. Press  to start the calibration. The belt will start running, based on the average forward speed entered at the beginning of the calibration routine (6.2).

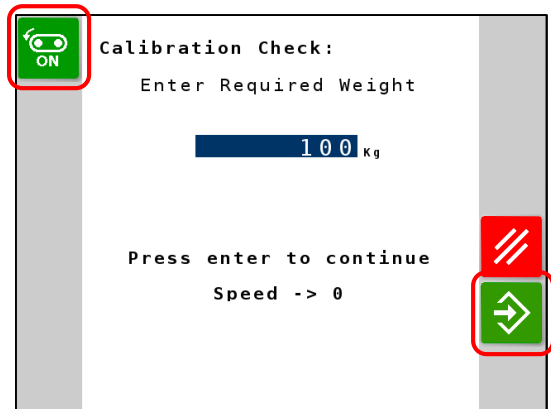

UK847-490.PNG

11. The display then counts up the theory weight (the weight the Apollo has calculated based on the calibration factors entered in step 3), and the live weight (the weight as measured by the loadcells).

The belt will automatically stop when the theory weight is reached.

12. Press  to switch the spreader off.

13. Press  to continue.

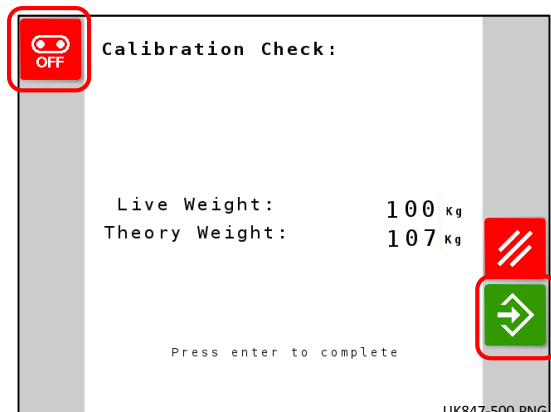

UK847-500.PNG

- If metering out a smaller weight that can be lifted by scales, then enter the weight that has been measured on to the weight entry page. For smaller weights, such as 40kg, it is advised not to use the live load cell weight for this calibration.

If dispensing a large volume of product (1000kg) back in to a bulk store, then enter the "Live Kg" that is shown from the load cells.

**NOTE:** To check Application Rate accuracy, dispense the TOTAL amount of product that is shown in hopper.

- Press  to continue.

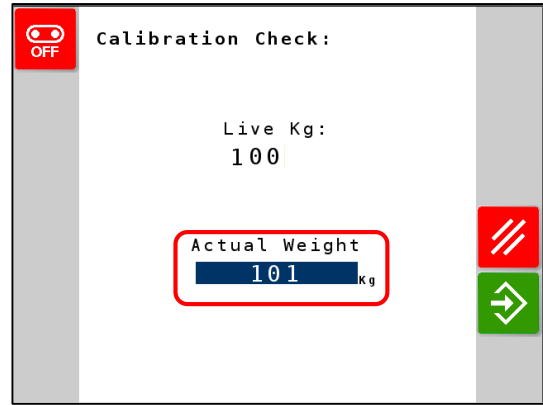

UK847-510.PNG

The flow factor is then recalculated and displayed.

**NOTE:** Increasing the flow factor has the effect of slowing the belt speed compared to the programmed density.

Decreasing the flow factor has the effect of increasing the belt speed compared to the programmed density.

"Dispensed weight" = "Theory weight".

- Press  to finish the calibration routine.

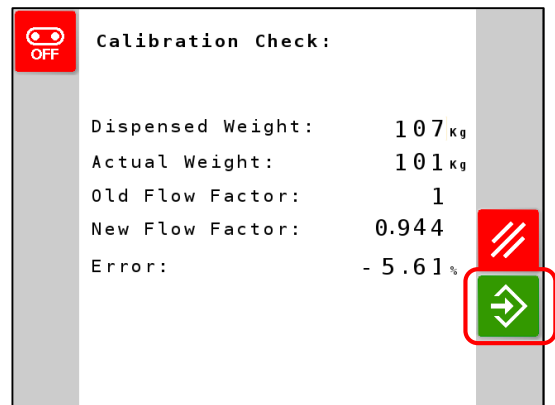

UK847-520.PNG

## 6.3 Nudge Calibration

Some discrepancy between the target weight and the actual weight can occur, often due to variations in the actual density of the product from the theoretical density programmed, or any product flow inconsistencies that may come from prilled or low friction products.

Whereas the "Check calibration" procedure (6.2.1) is a "snapshot" based on a limited quantity of product, the nudge procedure will adjust the flow factor by a % based on the variation between the actual and theoretical amounts dispensed over a longer working period.

- From the "Weight Setup" menu, press "Nudge Calibration".

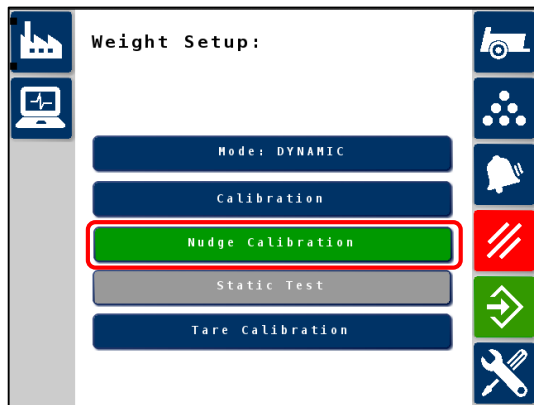

UK847-540.PNG

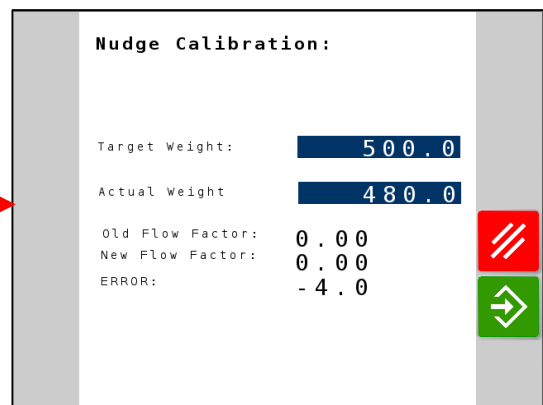

UK847-530.PNG

- Enter the 'Target Weight'
- Enter the 'Actual Weight' applied (the live kg total)  
The % error is then calculated and displayed.
- Press  to accept the new flow factor.

## 6.4 Loadcell calibration

It is possible that loadcells may drift out of calibration after an initial period of “bedding in” on a new machine.

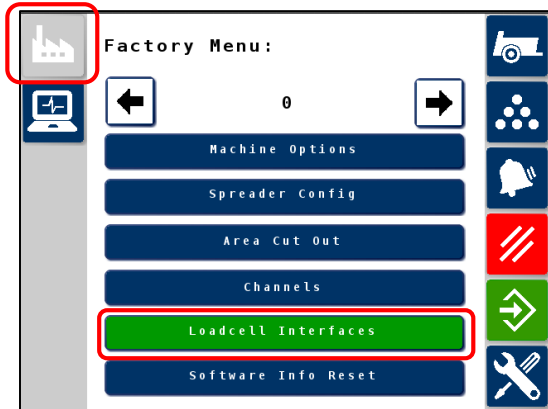

- From the “Main Menu” select the “Factory Menu” (  ) and then “Loadcell Interfaces > “Loadcell Calibration”.

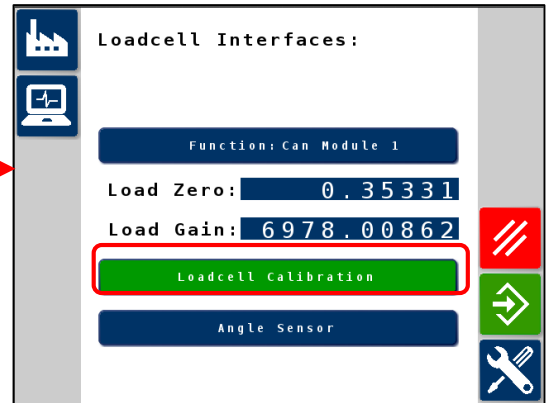

UK847-550.PNG



UK847-560.PNG

- If the hopper is empty, press “YES” and then  , then press  again to set zero.
- Otherwise press “NO”.

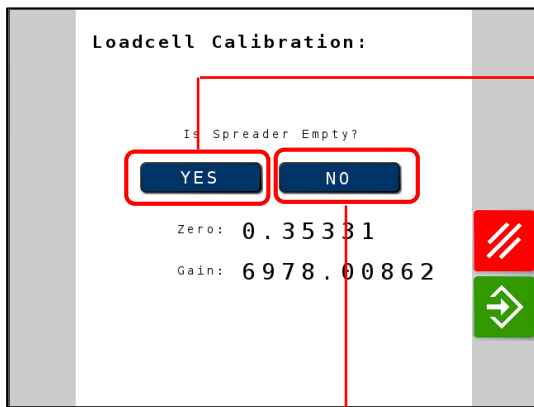

UK847-570.PNG

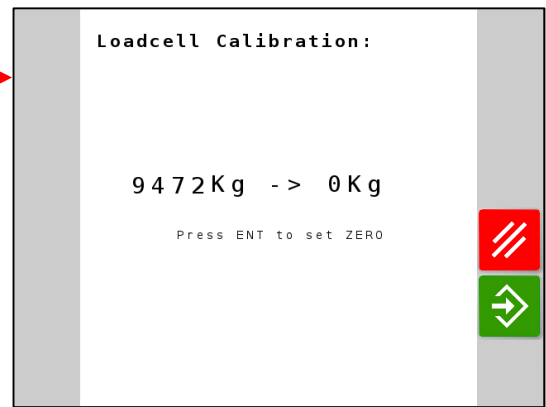

UK847-580.PNG

- With a pre-determined weight in the hopper, enter the known weight and press  to confirm.

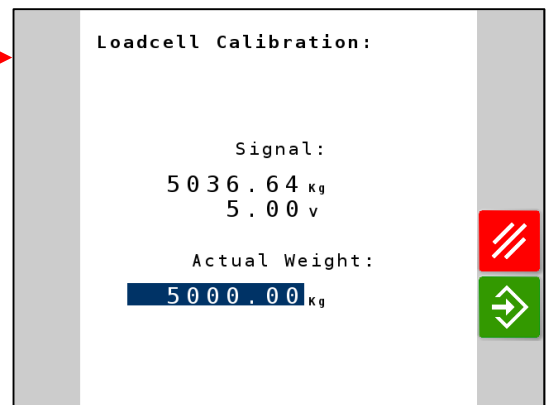

UK847-590.PNG

## 6.5 Valve calibration

- From the “Main Menu” select the “Factory Menu” (  ) and then “Channels > “Valve Setup””.

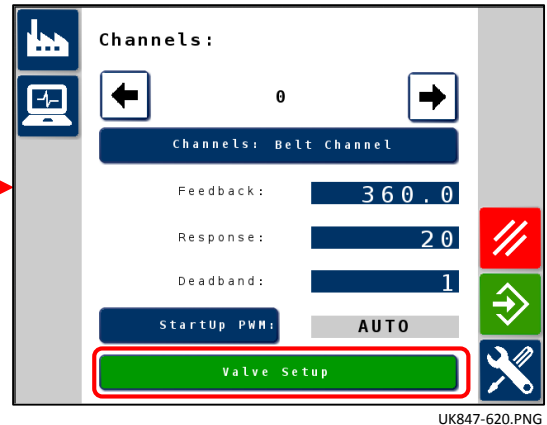
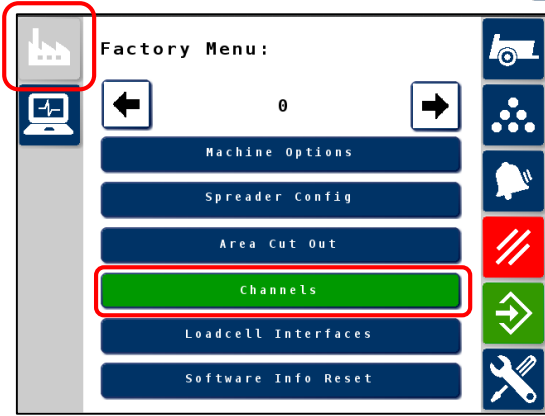

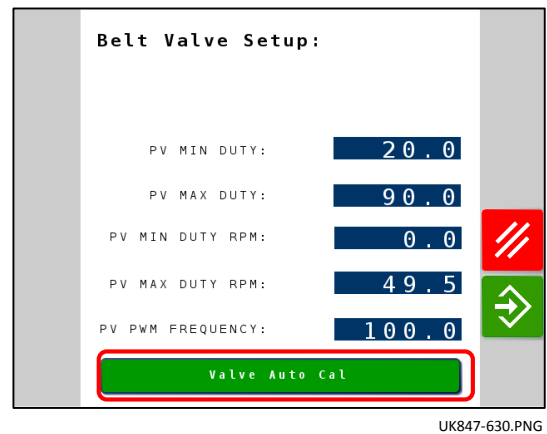

The “Belt Valve Setup” screen summarises the current valve settings.

- Select “Valve Auto Cal”, set the engine to normal operating rpm and press  to start the calibration procedure.

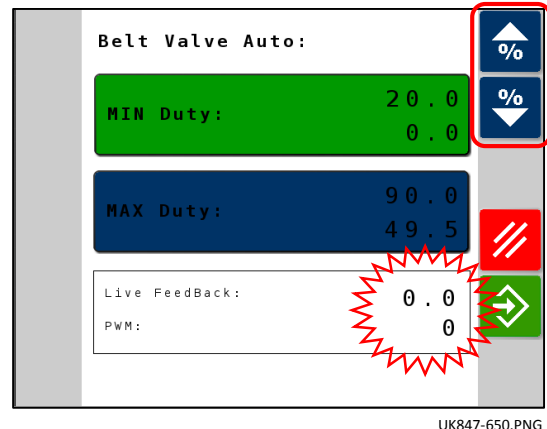

- With “Min Duty” selected, by observing the “Live Feedback” rpm value, adjust the belt until it is on the threshold of moving.
- Press  to set the minimum PWM output.



- With “Max Duty” selected, increase the belt speed to the maximum it can go.
- Press  to set the maximum PWM output.

The “Belt Valve Setup” screen then summarises the new settings.

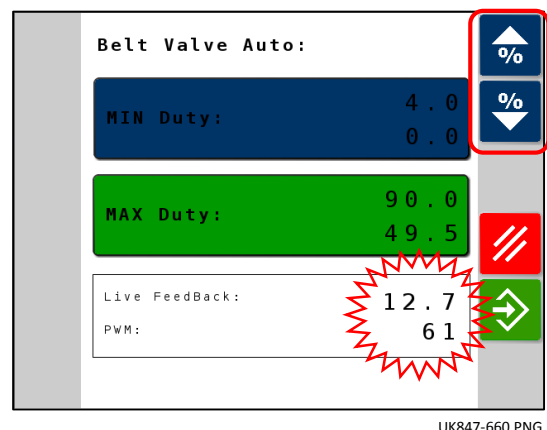

## 7. Appendices

### 7.1 Software upload

1. Copy the folder named "Apollo" onto the root directory of a USB memory stick, and insert at the rear of the X25 terminal.
2. Cycle to the Spreader Settings screen. From within the "Factory" menu, select "Software Info & Reset".

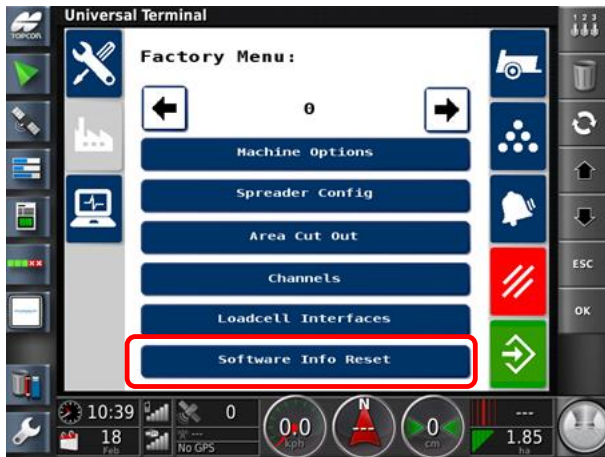

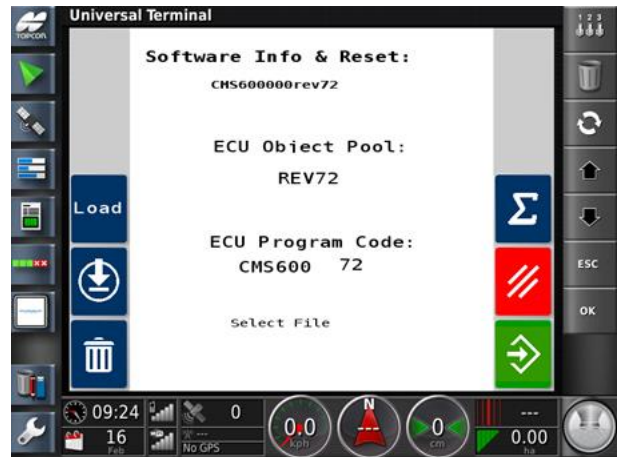

UK808-200.JPG



UK808-210.JPG

"ECU Object Pool" and "ECU Program Code" show what version of software is currently installed. At the top of the screen is displayed the new software number that is found on the USB stick, in this case CMS600-000rev72.

3. Press the top part of the display to display a drop-down menu showing a list of software versions found on the USB (see below). Ordinarily there will only be one valid software version – CMS600000revxx
4. Press  to select.
5. Press the highlighted 'Install' button (  ) and the existing factors will be saved onto the USB.

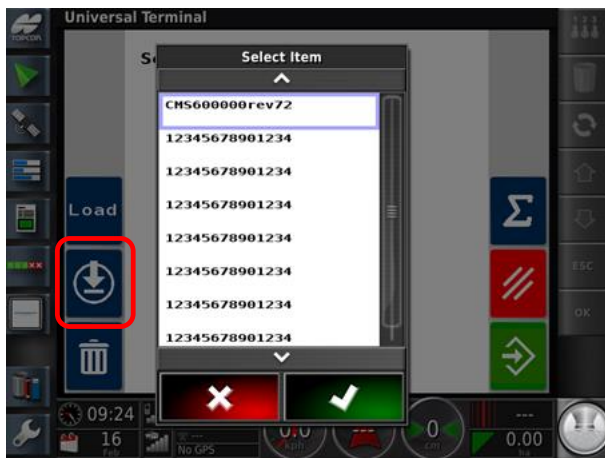

UK808-220.JPG

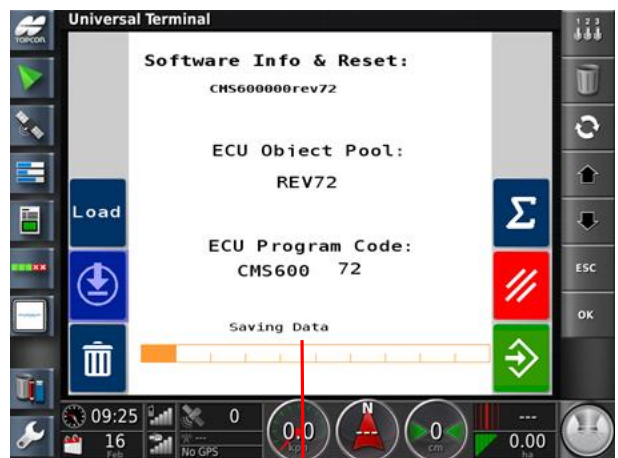

UK808-230.JPG

Once this has finished it will move onto 'Loading Software' ....

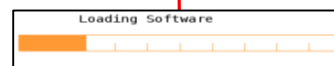

Followed by "Loading Object Pool".

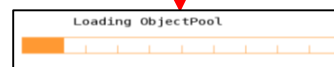

6. Once this has finished the screen will appear white and you must switch the instrument off and back on to trigger the new software to be reset.



7. After the instrument has powered up and the system re-loaded you can restore the previous settings by going back into the **Factory Menu** -> **“Software Info & Reset”** and press the **“Load”** button.
8. Once **‘Loading Factors’** has finished you must switch the instrument off and back on for the restored factors to take effect.

Update Complete!

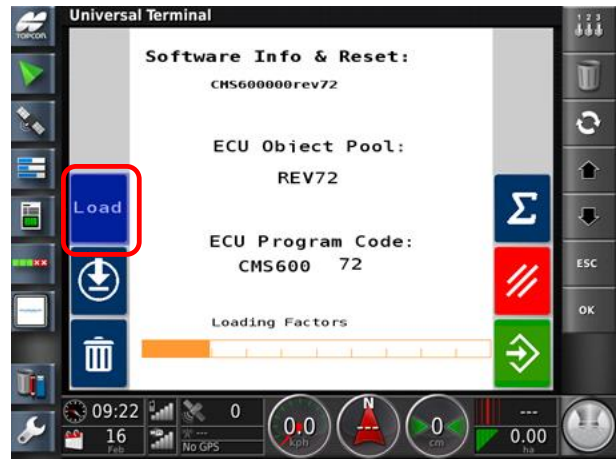

<b>Issue Ref.</b>	<b>Date</b>	<b>Notes</b>
A	5.4.16	1 <sup>nd</sup> draft